

Delta Environmental  
Products, Inc.

Pentair Water

# D2CX20-21

## Submersible Centrifugal Grinder Pump

Installation & Service Manual  
with Parts List

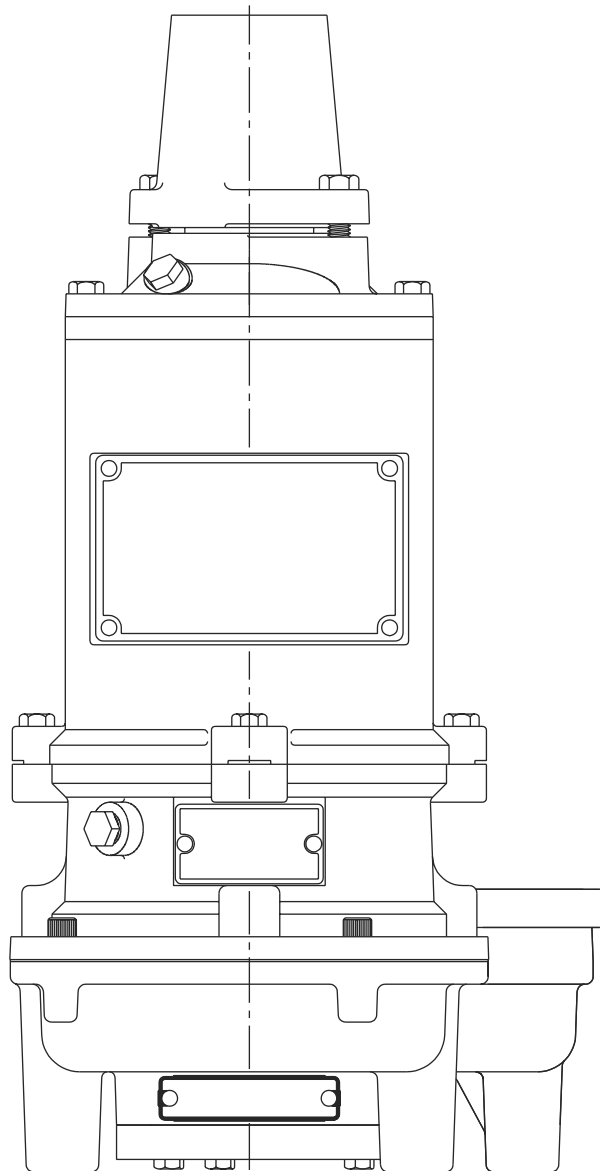

**NOTE!** To the installer: Please make sure you provide this manual to the owner of the pumping equipment or to the responsible party who maintains the system.

## SAFETY CAUTIONS AND WARNINGS

**MUST BE INSTALLED BY EXPERIENCED PROFESSIONALS ONLY**

**CAUTION: READ THESE SAFETY WARNINGS FIRST BEFORE INSTALLATION, SERVICING OR OPERATING ANY PUMP. THESE INSTRUCTIONS ARE WRITTEN WITH THE UNDERSTANDING THAT THE INDIVIDUALS) HAVE EXPERIENCE IN BUILDING WET WELLS AND INSTALLING BASINS, GRINDER PUMPS AND PUMPING EQUIPMENT.**

**NOTE:** Models with Third Party approval(s) are clearly marked on individual pump nameplates.

**▲ WARNING! RISK OF ELECTRICAL SHOCK. TO REDUCE RISK OF ELECTRICAL SHOCK, SEE INSTRUCTION MANUAL FOR INSTALLATION.**

**DO NOT REMOVE CORD AND STRAIN RELIEF.**

ALL THREE PHASE PUMPS MUST BE INSTALLED WITH MAGNETIC STARTERS HAVING THREE LEG OVERLOAD PROTECTION IN ACCORDANCE WITH THE NATIONAL ELECTRIC CODE. FOR DUPLEX INSTALLATIONS, BOTH PUMP MOTORS MUST HAVE SEPARATE OVERLOAD PROTECTION.

**▲ WARNING! ONLY QUALIFIED PERSONS SHALL CONDUCT SERVICES AND INSTALLATIONS OF THIS PUMP. THE PUMP MUST BE WIRED BY A QUALIFIED ELECTRICIAN.**

PUMPS WITH SEAL LEAK DETECTORS, MUST BE CONNECTED TO THE PROPER CONTROL CIRCUITRY. SEE INSTRUCTIONS MANUAL.

**▲ DANGER! HAZARDOUS MOVING PARTS. TO REDUCE RISK OF INJURY DISCONNECT POWER BEFORE SERVICING. NEVER PUT FINGERS NEAR GRINDER IMPELLER OR IN PUMP INLET WHEN PUMP CORD IS CONNECTED OR PUMP IS OPERATING.**

FOR USE WITH MAXIMUM 140°F LIQUID. ACCEPTABLE FOR OUTDOOR USE.

**▲ DANGER! IN THE INITIAL INSTALLATION, BEFORE SEWAGE IS ADMITTED TO THE BASIN, THERE IS NO DANGER ON ENTERING THE BASIN, BUT AFTER SEWAGE HAS BEEN IN THE BASIN THERE IS DANGER. SEWAGE WATER GIVES OFF METHANE AND HYDROGEN SULFIDE GASSES, BOTH OF WHICH ARE HIGHLY POISONOUS. A BREATHING DEVICE MAY BE REQUIRED. NEVER ENTER BASIN UNLESS COVER IS OPEN AND AN**

**OUTSIDE BLOWER IS USED TO FORCE FRESH AIR INTO THE BASIN. ALSO, THE WORKER IN THE BASIN MUST WEAR A HARNESS ATTACHED TO THE SURFACE SO THAT HE CAN BE PULLED OUT IN CASE OF ASPHYXIATION. NEVER WORK ALONE!**

**▲ WARNING! DO NOT EXCEED WORKING LOAD LIMIT OF LIFTING ROPE OR CHAIN. DO NOT USE LIFTING ROPE OR CHAIN WHERE FAILURE COULD RESULT IN LOSS OF LIFE.**

**EXAMINE ALL LIFTING DEVICES, ROPE OR CHAIN FOR DAMAGE BEFORE AND AFTER EACH LIFT.**

**DO NOT USE ANY LIFTING DEVICES THAT ARE NOT RATED FOR AND DESIGNED TO LIFT THE WEIGHTS INVOLVED WITH THESE PUMPS.**

**DO NOT INSTALL OR REMOVE PUMP WITH PERSON(S) IN BASIN.**

### GENERAL

1. Most accidents can be avoided by using **COMMON SENSE.**
2. Read the operation and maintenance instructions manual supplied with the pump.
3. **DO NOT** wear loose clothing that can become entangled in the impeller or other moving parts.
4. This pump is designed to handle materials which could cause illness or disease through direct exposure.

Wear and use protective clothing when working on the pump or piping.

### ELECTRICAL

1. **To reduce the risk of electrical shock, pump must be properly ground in accordance with the National Electric Code and all applicable state and local codes and ordinances.**
2. **To reduce risk of electrical shock,** disconnect the pump from the power source before handling or servicing.
3. Any wiring to be done on pumps should be done by a qualified electrician.
4. **NEVER** operate a pump with a power cord that has frayed or brittle insulation.
5. **NEVER** let cords or plugs lay in water.
6. **NEVER** handle connected power cords with wet hands.

## PUMP CAUTIONS AND WARNINGS

### PUMP

1. Pump builds up heat and pressure during operation, allow time for pump to cool before handling or servicing.
2. Only qualified personnel should install, operate or repair pump.
3. Keep clear of suction and discharge openings. **DO NOT** insert fingers in pump with power connected.
4. **DO NOT** pump hazardous material not recommended for pump (flammable, caustic, etc.).
5. Make sure lifting devices are securely fastened each time before lifting pump.
6. **DO NOT LIFT PUMP BY THE POWER CORD.**
7. **DO NOT** exceed manufacturer's recommendation for maximum performance, as this could cause the motor to overheat.
8. Secure the pump in its operating position so it cannot tip over, fall or slide.
9. Keep hands and feet away from impeller when power is connected.
10. Submersible grinder pumps are not approved for use in swimming pools, recreational water installations, decorative fountains or any installation where human contact with the pumped fluid is common.
11. **DO NOT** pump without safety devices in place.
12. For hazardous locations, use pumps that are listed and classified for such locations.
13. **DO NOT** use non-explosion proof rated pumps in locations considered hazardous in accordance with the National Electrical Code, ANSI/NFPA 70-1993.
14. Basin must be vented in accordance with the local plumbing codes.

**IMPORTANT:** Manufacturer is not responsible for losses, injury or death resulting from failure to observe these safety precautions, misuse or abuse of pumps or equipment.

### CONTROL PANELS

All control panels used on these grinders are UL listed and CSA certified. Control panels mounted directly to the basin used outdoors are UL listed and CSA certified waterproof.

If intrinsically safe controls used in hazardous locations are required, manufacturer can furnish a UL listed or CSA certified panel. Otherwise the installer must obtain a source for the panel required.

### LEVEL SENSING CONTROLS

Intrinsically-safe type float controls are recommended for all applications and required for explosion-proof service. An intrinsically safe control panel relay will limit the current and voltage to the level controls. A Delta control panel can be supplied with this type circuitry.

The float level controls maintain the basin sewage water level by controlling pump turn-on and turn-off level.

1. The lower turn-off control should be set so that the pump stops at approximately the top of the pump.
2. The upper turn-on control should be set above the lower turn-off control. The exact height between the two controls is determined by the number of pump starts desired and the depth of the basin. A maximum of 10 starts per hour should not be exceeded.
3. The override control is set at a specified height above the upper turn-on control.
4. The alarm control is set about 6" to 12" above the override control.
5. No control should be set above the inlet invert.

### JUNCTION BOXES

If a junction box is used in a hazardous location, it must be an explosion-proof approved type with explosion-proof cord connectors. Wires from the junction box must pass through an explosion-proof seal connector.

**CAUTION:** No persons should be in the basin when pump is lowered into position! **DO NOT** lift pump in a manner where any failure could result in loss of life.

### AIR VENTING

Air tends to trap in the pump volute when water raises in the sump or when the pump is lowered into water after service. To vent off this air, a small hole is drilled into the pump volute. **Be sure this vent hole is clean after any service work on pump.**

**PUMP MODELS** — This grinder pump is made in one model only for use with single phase and three phase power. Motor rating is 2 HP, 3540 RPM, 60 Hz. Also can be used for 50 Hz. operation. Single phase is for 230 volt.

**PACKAGING** — Each pump is packaged with 15 feet of power cord in a carton that is marked with Model Number and Engineering Number. Longer cords are available for special jobs.

**INSTRUCTIONS** — Instructions cover only the pump unit. Separate instructions for the electrical control panel and basin packaged system are included with these items.

**CAUTION:** PUMP IS NOT TO BE DISASSEMBLED IN THE FIELD EXCEPT AT CERTIFIED SERVICE STATIONS OR AT FACTORY. WARRANTY IS VOID IF PUMP IS TAKEN APART FOR ANY REASON EXCEPT TO REPLACE GRINDER IMPELLER AND GRINDER RING WHICH IS COVERED IN THESE INSTRUCTIONS.

## PUMP INSTALLATION

**DESCRIPTION OF PUMP** — This pump is intended to grind and pump all normal sewage for home or commercial use. It will also handle reasonable quantities of disposable diapers, sanitary napkins, paper towels, rubber material, wood, plastic, string, cigarette butts and other material not normally found in sewage.

Pump is of heavy duty construction and submersible type for long life when pumping ground sewage. Motor is capacitor start, capacitor run for single phase. Capacitors and start relay are mounted in electrical control box.

Pump has two oil-filled chambers: (1) the motor and ball bearings and (2) the seal chamber - for long life and best heat transfer.

The lower seal above the pump impeller acts as a buffer for upper seal that holds oil in the motor chamber. If lower seal leaks for any reason, water enters the seal chamber. If motor has the seal leak detector, the electrode will contact the water and close the circuit to the red seal light in the control panel indicating motor must be serviced before upper seal fails.

A heat sensor is attached to stator winding to sense any abnormal heat. If motor temperature for any cause rises above 221°F the pump is immediately stopped and will not restart until motor cools to a safe temperature.

**PUMP CORDS** — Each pump has two cords. The power cord contains 4 conductors and the control cord has 5 conductors. The larger of the two cords is the power cord and smaller cord is the control cord.

The power cord for single phase uses the color coding for start and main windings and connects to control box terminal strip black (common), white (run), and red (start). The green wire is always ground and connects to ground terminal in control box. For three phase the same 4 conductor color coded cords are used, the black, white and red can be connected to any of the three phase terminals in the control box.

The smaller control cord uses black and white leads for heat sensor and connects to terminal strip in control box. The red and orange wires connect to seal failure terminals in control box and the green or ground lead connects to ground terminal in control box.

**IMPORTANT** — Ground wires must be connected in the control box to grounding bar, which is connected to a good outside ground. **MOTOR IS NOT SAFE UNLESS GROUNDED.**

**INSPECTING PUMP** — Before making any piping or electrical connections check pump for any shipping damage and turn grinder impeller to be sure it is free. **DO NOT TURN IMPELLER WITH FINGERS AS EDGES ARE SHARP**, use socket wrench in the impeller screw.

**CAUTION:** After pump is installed **NEVER WORK ON MOTOR OR GRINDER UNIT WITHOUT DISCONNECTING MOTOR LEAD WIRES FROM CONTROL PANEL. DO NOT RELY ON OPENING CIRCUIT BREAKER ONLY.**

**INSTALLING PUMP IN BASIN** — Complete installation and piping instructions are included with the basin package.

To check rotation turn Hand-Off-Auto switch to OFF position and turn on circuit breaker. Quickly turn H-O-A switch to HAND position, then OFF. Note grinder impeller rotation. Impeller must rotate counterclockwise. If rotation is wrong, change any two line leads to motor at control box terminal. Recheck for proper rotation. **CAUTION: KEEP HANDS COMPLETELY AWAY FROM GRINDER IMPELLER WHEN MAKING THIS CHECK.**

Where pump is installed remote from control box in outside installation a different method is used.

Set the pump in the basin and run in some water so pump can operate. Turn H-O-A switch to hand position and let pump pull water down in basin. When water reaches the bottom of pump, rotation of the water can be observed. Water should rotate in a clockwise direction if pump rotation is correct. If not correct rotation, interchange any two line leads to motor at control panel.

When replacing a pump with a new unit, rotation must be checked.

# PUMP PARTS LIST

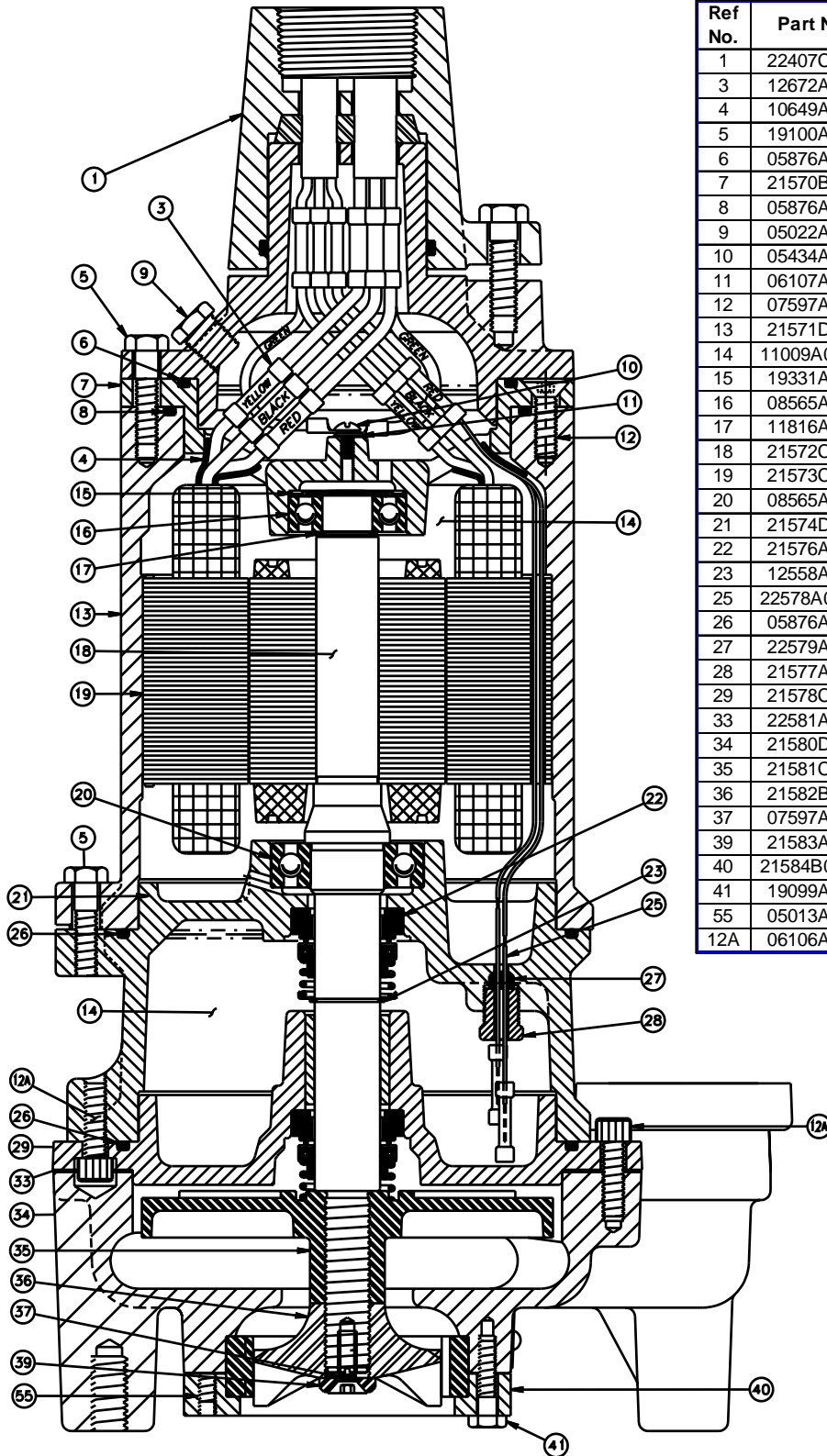

Ref No.	Part No.	Description	Qty.
1	22407C100	Cord Cap	1
3	12672A001	Connector	7
4	10649A102	Tube, Plastic	2
5	19100A012	Cap Screw, 5/16"-18 x1 1/4" Lg.	8
6	05876A122	Gasket, Rubber Tetraseal	1
7	21570B100	Cap, Upper Bearing	1
8	05876A123	Gasket, Rubber Tetraseal	1
9	05022A092	Pipe Plug, 1/4" NPT, Hex HD.	2
10	05434A043	Screw, Mach., #10-24 x1/2" Lg.	1
11	06107A015	Lock Washer, #10	1
12	07597A017	Screw, Mach., Flat Hd.	2
13	21571D100	Housing, Motor	1
14	11009A003K	Oil, Transformer	1.06
15	19331A005	Washer, Spring	2
16	08565A013	Bearing, Ball	1
17	11816A006	Ring Retaining	1
18	21572C100	Rotor, w/Shaft	1
19	21573C100	Stator	1
20	08565A018	Bearing, Ball	1
21	21574D100	Housing, Upper Seal	1
22	21576A010	Seal, 7/8" Shaft	2
23	12558A006	Ring Retaining	1
25	22578A004A	Electrode	2
26	05876A125	Gasket, Rubber Tetraseal	2
27	22579A000	Ferrule, Rubber	1
28	21577A000	Plug, Special	1
29	21578C100	Housing, Lower Seal	1
33	22581A001	Gasket, Vellumoid	1
34	21580D102	Casing, Volute	1
35	21581C500	Impeller, Pump	1
36	21582B000	Impeller, Grinding	1
37	07597A018	Mach. Screw, 1/4"-20 x1" Lg.	1
39	21583A000	Retainer, Impeller	1
40	21584B000K	Flange, w/Shredding Ring	1
41	19099A012	Cap Screw, Hex 1/4"-20 x1" Lg.	3
55	05013A039	Set Screw, 1/4"-20 x3/8" Lg.	2
12A	06106A008	Cap Screw, 5/16"-18 x1" Lg.	8

Fig. 1

## REPLACING PARTS AND DISMANTLING PUMP

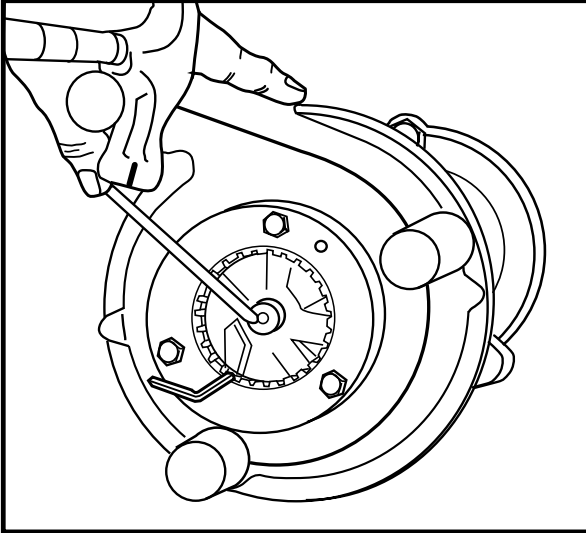

Fig. 2

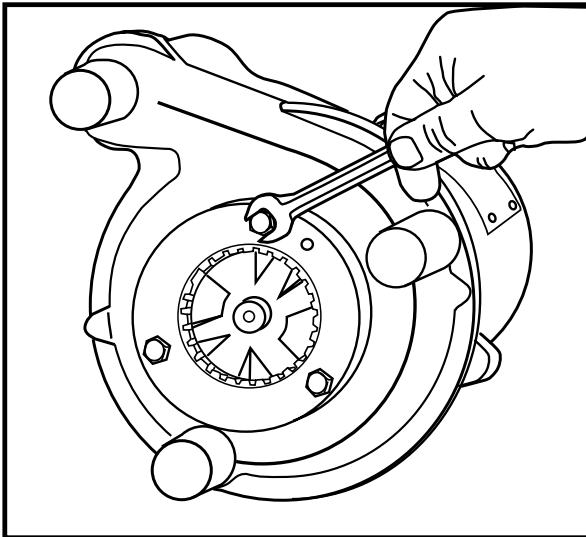

Fig. 3

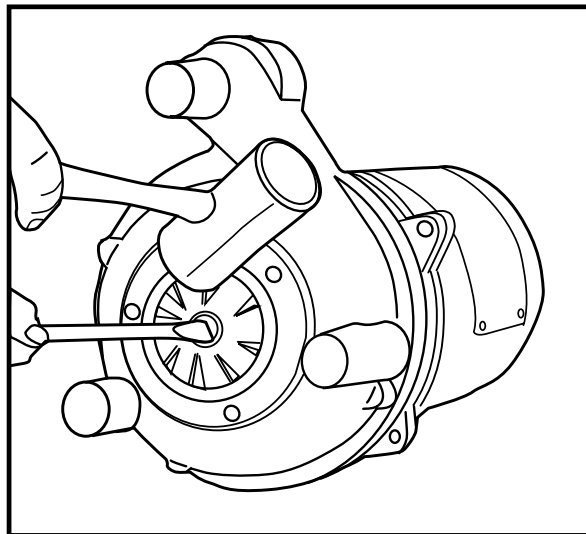

Fig. 4

### REPLACING PARTS AND COMPLETE DISMANTLING OF PUMP

#### Standard Tools Required:

1. Allen head socket set
2. Standard socket wrench set
3. Set of open end wrenches.
4. Plastic hammer
5. Vise grip pliers
6. Large screwdriver with heavy handle
7. Wire brush
8. Three-cornered file
9. Flat file
10. Snap ring pliers for outside snap ring
11. Crimping pliers for electrical connectors
12. Arbor press
13. Loctite #271
14. Submersible motor oil

**IMPORTANT**— Before any repair work is done on pump it should be sandblasted, if possible, to remove any deposits. After cleaning, pump should be submerged in a strong "clorox" solution for one hour before handling pump.

**CAUTION: DISCONNECT ALL POWER AND CONTROL WIRES TO MOTOR AT CONTROL PANEL BEFORE STARTING DISASSEMBLY OPERATIONS. NEVER RELY ON OPENING CIRCUIT BREAKER ONLY.**

#### DISASSEMBLY OF SHREDDING RING AND GRINDER IMPELLER

1. Hold impeller from moving by placing small allen wrench or screwdriver in shredding ring slot and remove socket head screw and washer from pump shaft. See Figure 2.
2. Remove three screws from grinder ring flange. Grinder ring is pressed into flange for easy removal. See Figure 3.
3. Thread two screws into tapped back-off holes in flange and evenly tighten screws to back grinding ring out of pump housing.
4. Place large flat blade screwdriver into slot in shaft.
5. Bump impeller vane counterclockwise with plastic hammer to loosen impeller and continue to unscrew impeller from shaft. See Figure 4.

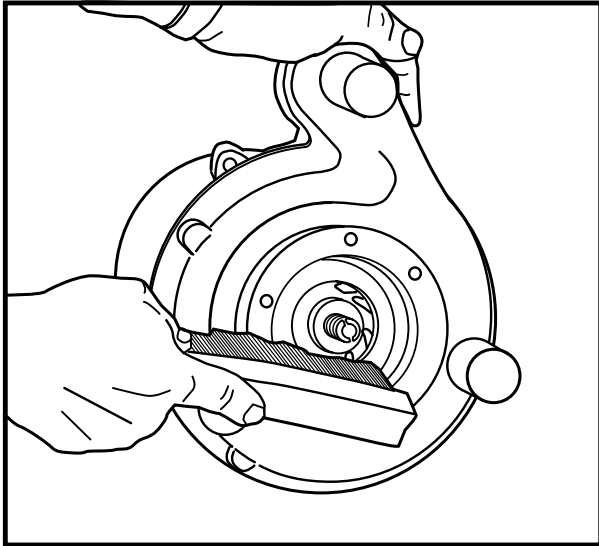

Fig. 5

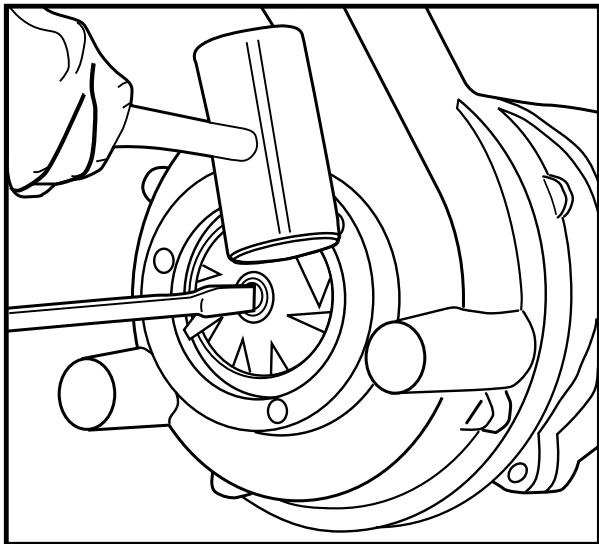

Fig. 6

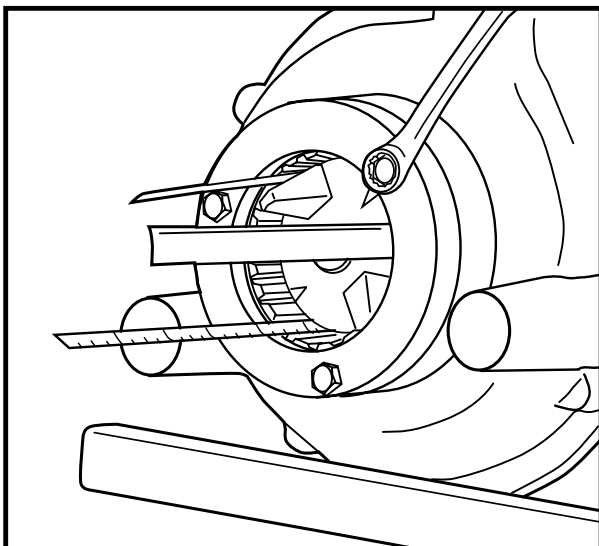

Fig. 7

6. Use wire brush and thoroughly clean any deposit from passage above grinder impeller and in cavity for grinder ring. See Figure 5.
7. Replace new grinder impeller, use screwdriver in slot while turning on impeller, until hand tight, with screwdriver still in shaft slot bump with plastic hammer. See Figure 6.
8. Replace new grinder ring and plate. Use oil on ring for easy fit.
9. To provide proper alignment use three sections of an old 1/2" tape measure as shims 120 degrees apart and then tighten bolts. Be sure to pull screws down evenly applying pressure on all three screws. **DO NOT TIGHTEN ONE SCREW CLEAR DOWN BEFORE ADJUSTING OTHER SCREWS.** See Figure 7.
10. Replace holding screw and washer, use small amount of Loctite #271 screw. See Figure 8
11. Bump set screw wrench with plastic hammer to tighten, working against small allen wrench or screwdriver in shredding ring.
12. Check freedom of rotation using finger on impeller vanes. Pump should turn free with slight drag due to seals. Use caution to avoid injury from shredding ring while turning grinding impeller.
13. As a final check, measure distance from end of ring to bottom of impeller vanes. This should be 3/32" to 1/8". If distance is only 1/16" or less it will indicate pump impeller has partially unscrewed when grinder impeller was removed. See Figures 9 and 10. If this is the case, pump case will have to be removed to tighten pump impeller. These steps will be given in the following instructions. In rare cases if the impeller is jammed so tight it can't be removed by the steps given it will be necessary to remove the motor housing so that the motor rotor can be gripped to break loose the grinder impeller. See Figure 11.

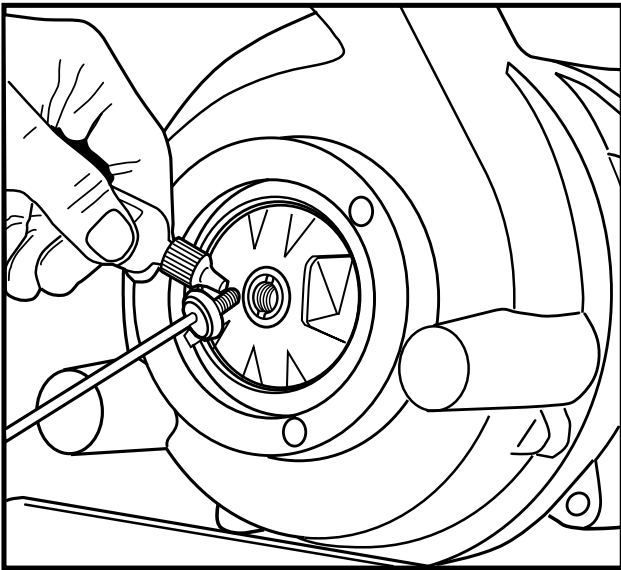

Fig. 8

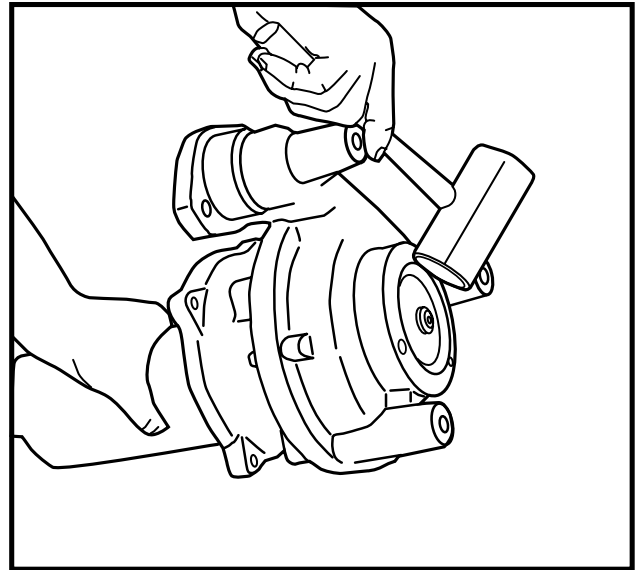

Fig. 11

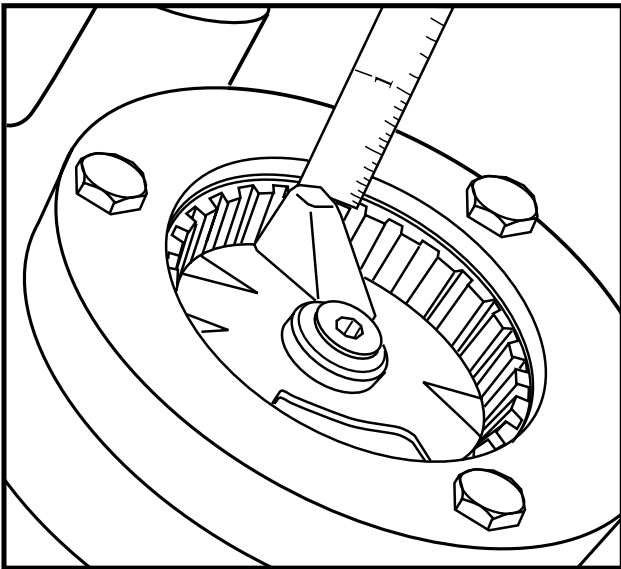

Fig. 9

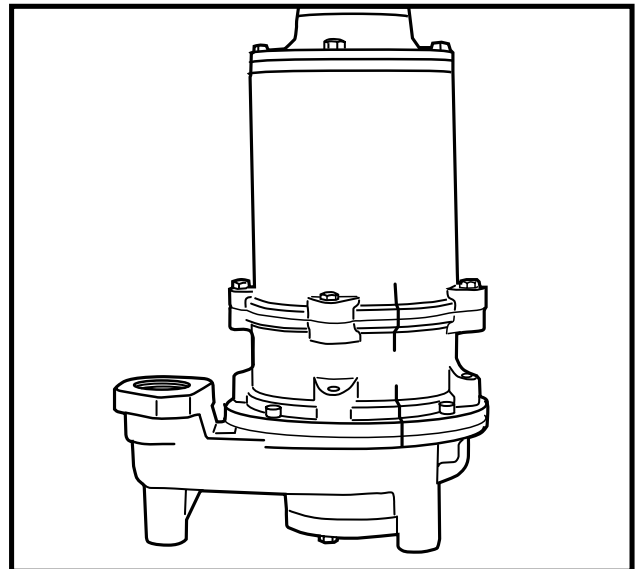
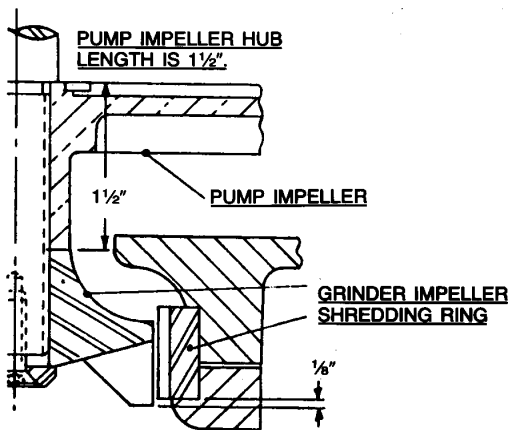

Fig. 12



**"PROPER SETTING OF GRINDER IMPELLER."**  
IMPELLER VANE TIPS EXTEND ABOUT 1/8"  
BELOW BOTTOM OF SHREDDING RING.

Fig. 10

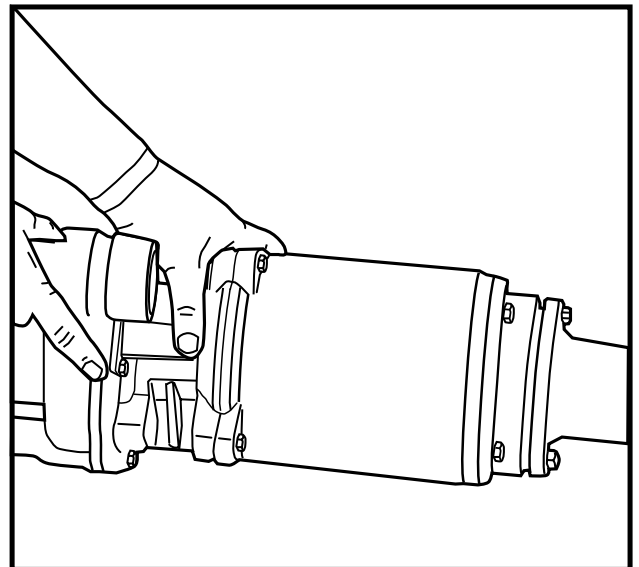

Fig. 13

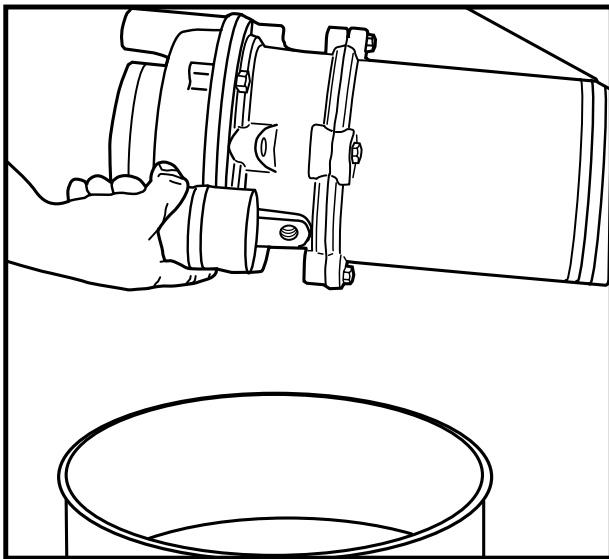

Fig. 14

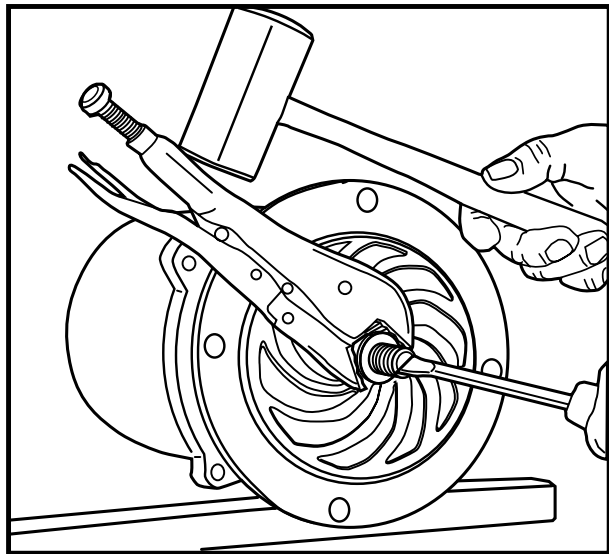

Fig. 15

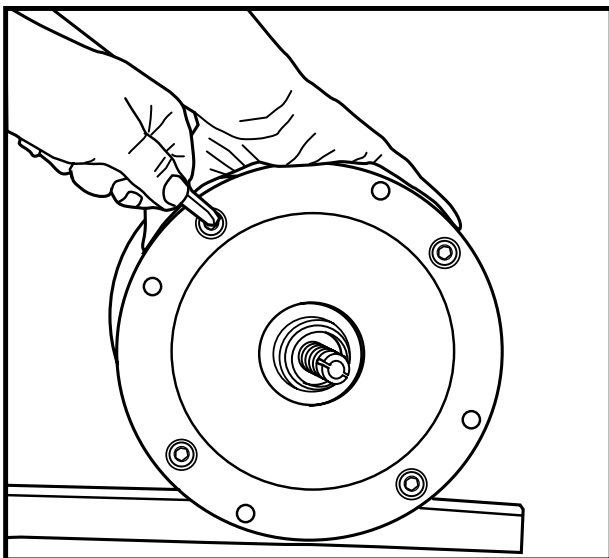

Fig. 16

## REPLACING LOWER SEAL

1. Use steps 1 through 5 for removing grinder ring and grinder impeller.
2. Before removing any other parts use a marking pen to mark joining parts so that they can be replaced in same position as removed. See Figure 12.
3. Remove oil fill plug slowly from seal chamber as pressure may have built up in this cavity, and pour out oil. See Figures 13 & 14.
4. Remove volute case bolts and pull off volute casing. Plastic hammer can be used to bump on casing discharge to loosen. Place gasket in oil to prevent drying out.
5. Insert large flat blade screwdriver in slot provided in pump shaft and hold impeller hub with vise grip pliers. Turn impeller counter-clockwise to loosen. It may be necessary to give pliers a sharp blow with plastic hammer to loosen impeller. See Figure 15. Turn counter-clockwise to loosen.
6. Use wire brush and putty knife and clean casting before removing seal.
7. Remove Allen socket head screws from seal plate. See Figure 16.
8. Pry carbon portion of seal from shaft by using flat blade screwdrivers on each side of shaft. **DO NOT SCRATCH SHAFT.** It does not matter if carbon cracks as it may be replaced with new part. See Figure 17.
9. Remove ceramic seal face and rubber retaining boot by prying seal out with flat blade screwdrivers. (Seal can be pressed out with a screwdriver from the opposite side.) Be careful not to scratch bronze bushing. Damage to seal is not important, as a new part must be installed. See Figure 18.
10. Thoroughly clean inside of seal chamber and pocket where new seal is to be installed. See Figure 19. Use rags and solvent cleaner.
11. Use care to avoid touching sealing faces with hands, use protective cardboard circle provided with seal, while handling. Use an artists brush to coat bottom outside portion of rubber retaining boot with conservative application of STP or equivalent lubrication to ease installation. See Figure 20.

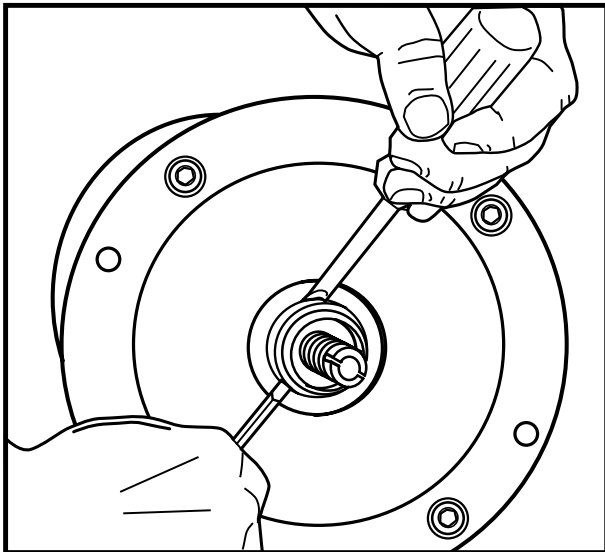

Fig. 17

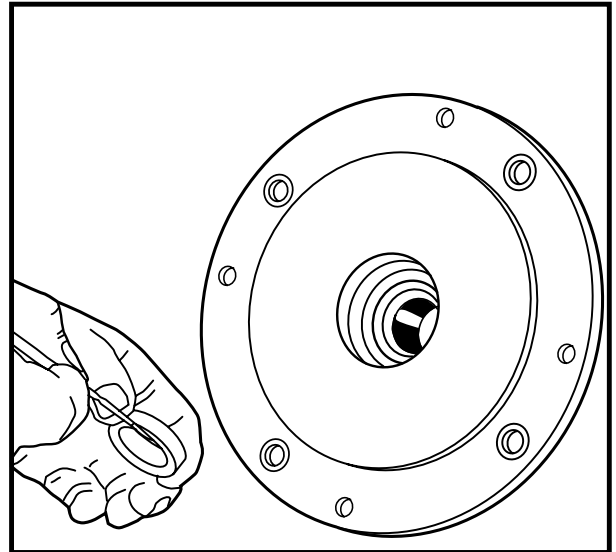

Fig. 20

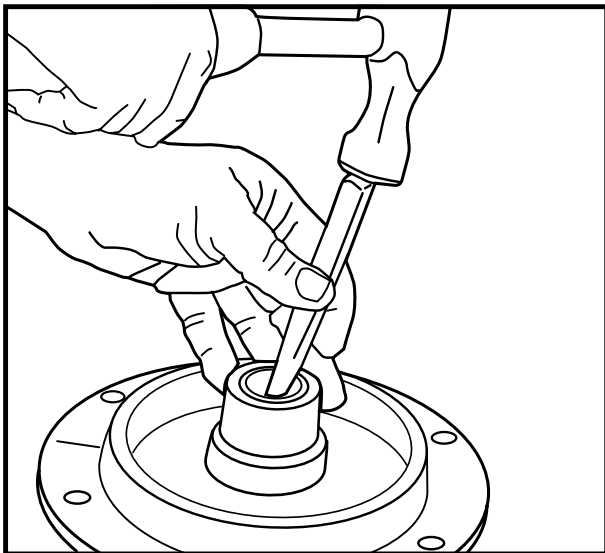

Fig. 18

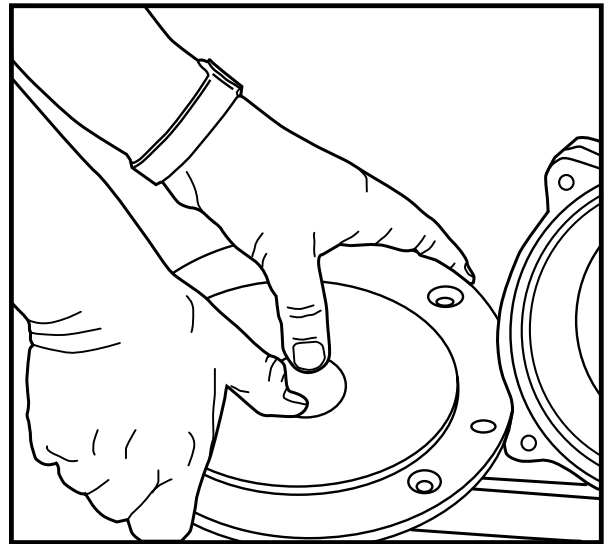

Fig. 21

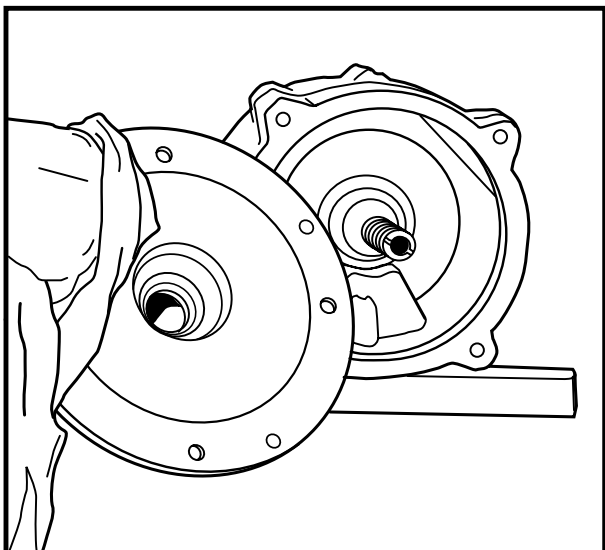

Fig. 19

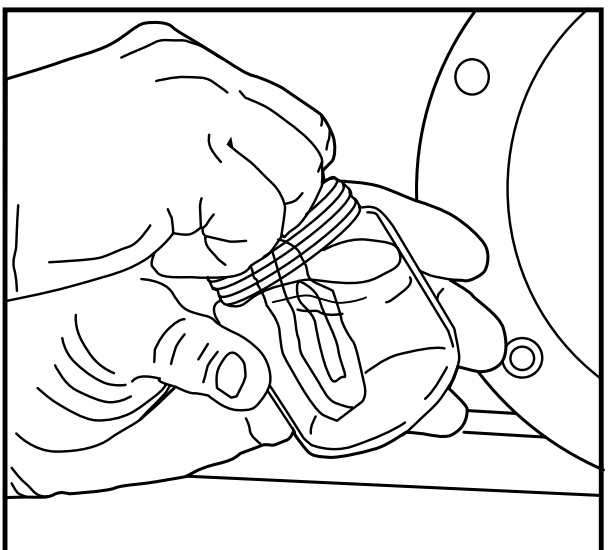

Fig. 22

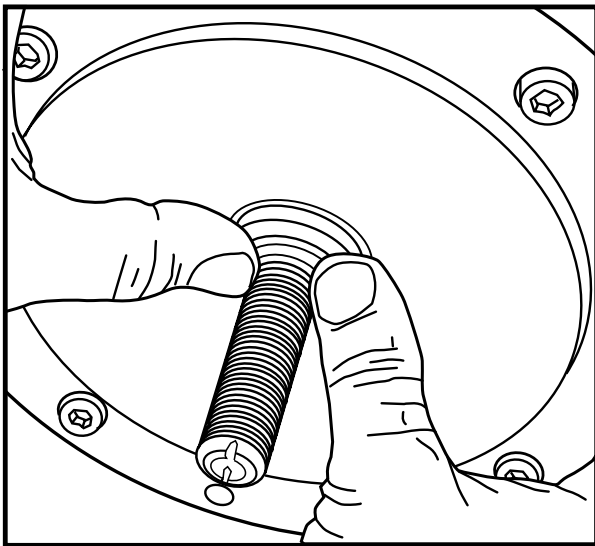

Fig. 23

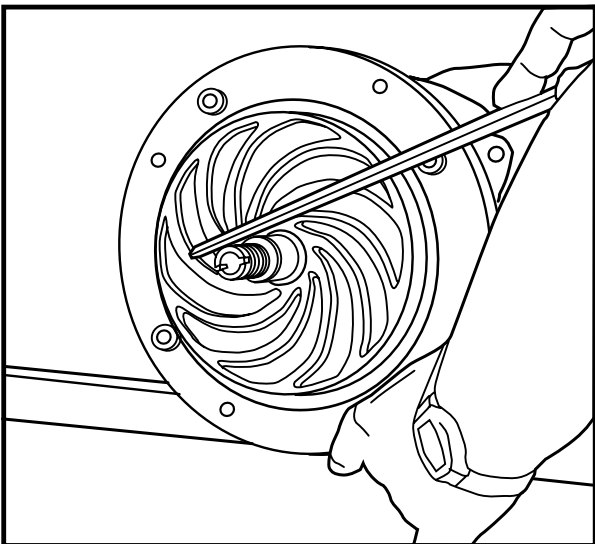

Fig. 24

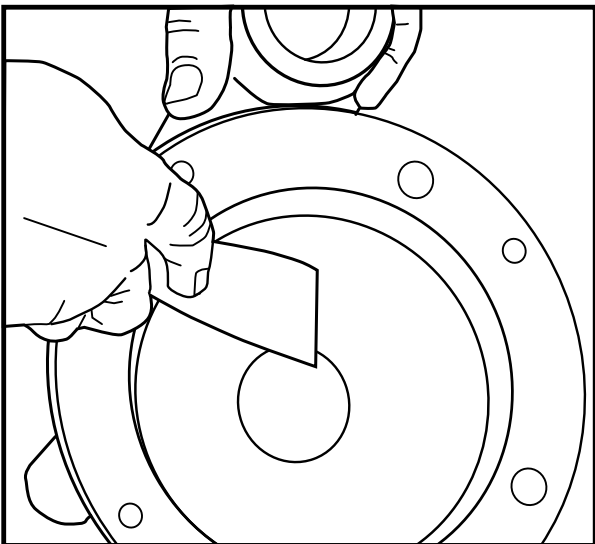

Fig. 25

12. Place seal in seal cavity loosely and using cardboard protector use both thumbs to press seal into seal plate. The cardboard protector can be moved about to insure seal is pressed in evenly. See Figure 21.
13. Wetting finger and touching center of cardboard protector will allow it to be easily removed.
14. Coat lower rubber shaft boot portion of carbon half of rotary seal with conservative application of STP or equivalent lubricant. Next immerse seal in small container of Transformer Oil (small baby food jar recommended). See Figure 22. Firmly press seal on shaft using thumbs. Observe that carbon seal is firmly in contact with ceramic portion of seal, and that carbon portion has not slipped out of its metal holder. See figure 23. Install spring for lower seal only. **NOTE:** Discard spring retaining ring provided with the seal, as a groove is machined in the back side of the bronze impeller to locate and retain this seal spring.
15. Replace impeller and tighten with vise grip pliers, holding shaft with large flat blade screwdriver.
16. File off any burrs made on impeller neck with vise grip pliers. See figure 24.
17. Clean casing thoroughly with wire brush and wash out with solvent. Be sure the discharge port and small weep hole in the volute case is clean and free of any deposits. See Figure 25.
18. Replace volute case being careful to have gasket in place. Line up with center marks made before dismantling pump. See Figure 26.
19. Replace grinder ring and impeller as described under "Replacing Grinder Ring & Grinder Impeller".
20. Air test repaired pump with approximately 6 lbs. of air pressure using piping with pressure gauge and air valve stem. Submerge in water and after evacuating air from volute case observe for leaks, remove and dry off pump.
21. Refill seal chamber with Transformer Oil. See Figure 27. Fill until oil is  $\frac{3}{4}$ " below top of oil plug boss. See Figure 28.
22. Clean oil plug with wire brush, reapply Teflon tape and reinstall oil plug.
23. In rare case when impeller is locked too tight to remove as described, it may be necessary to lift off the motor housing so that rotor can be held while impeller is removed.

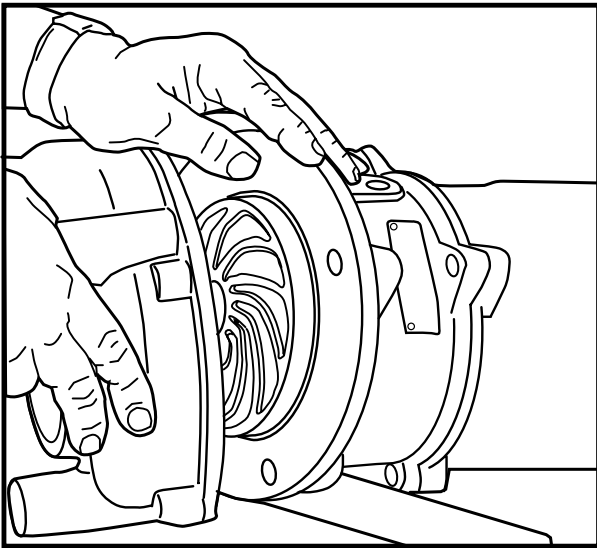

Fig. 26

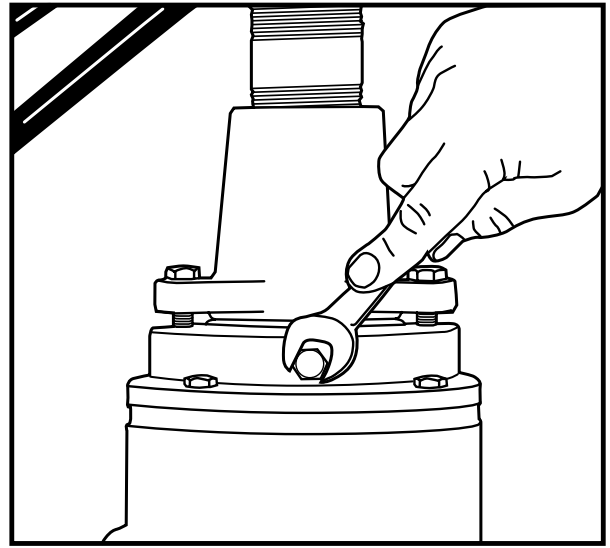

Fig. 29

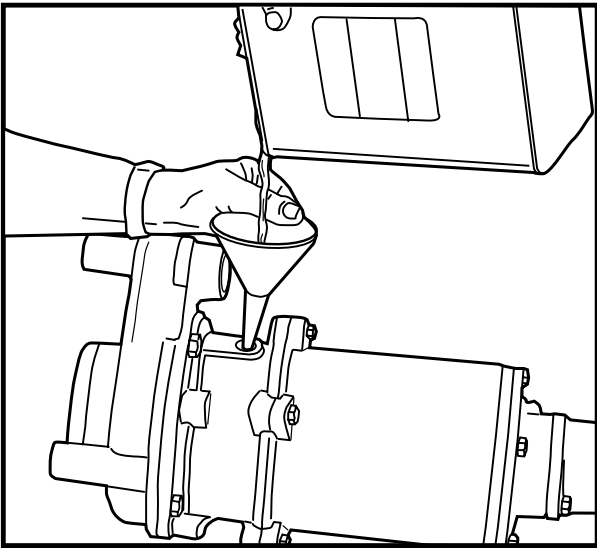

Fig. 27

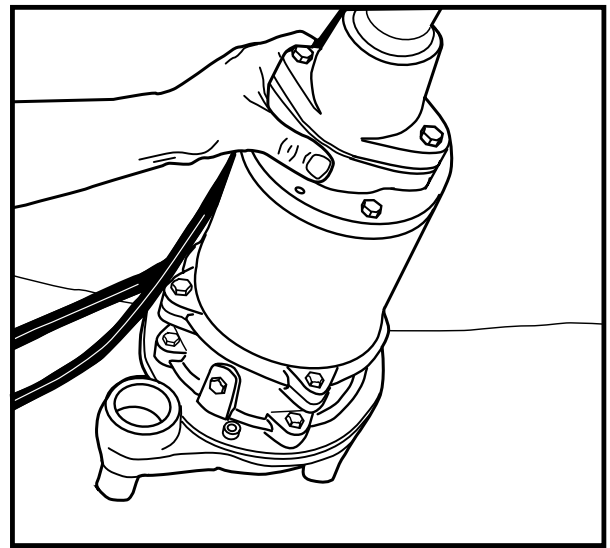

Fig. 30

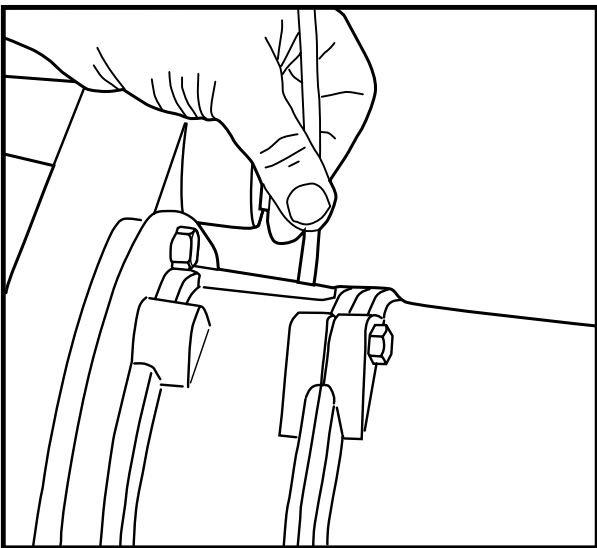

Fig. 28

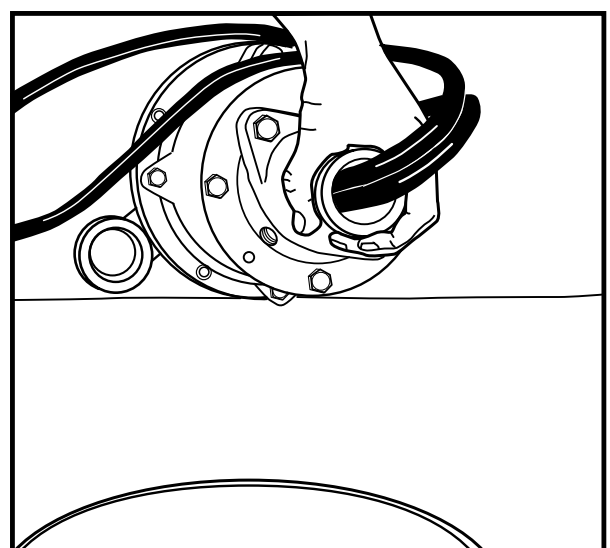

Fig. 31

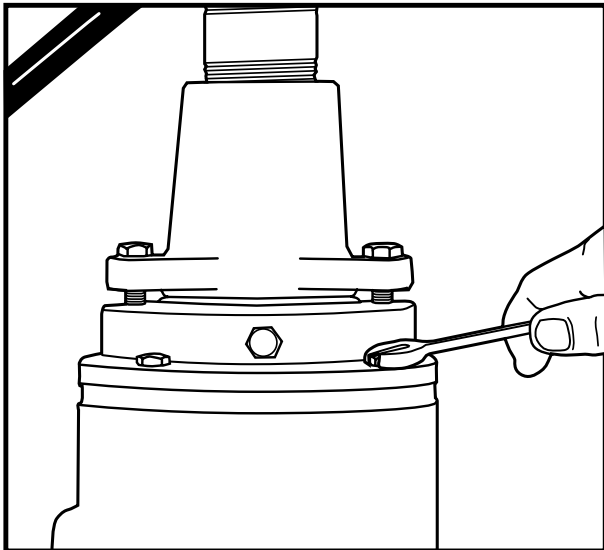

Fig. 32

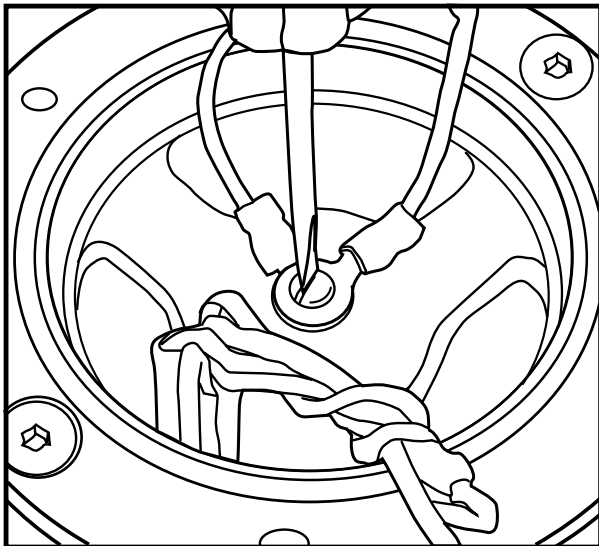

Fig. 33

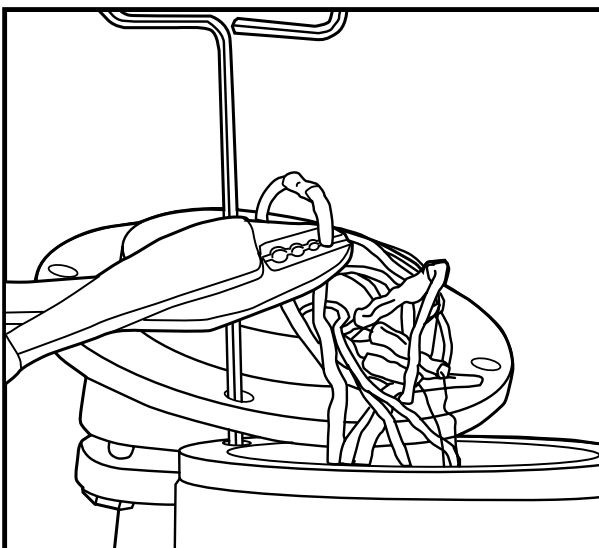

Fig.34

## REPLACING UPPER SEAL

To replace upper seal it is necessary to completely dismantle the pump. Usually if upper seal is out, the motor stator will be ruined with water, so it will also be necessary to be replaced.

1. Remove oil fill plugs slowly and drain oil from motor and seal chamber. See Figures 29, 30 and 31.
2. Remove motor end cap screws and thread into tapped back-off holes to force cap from motor housing. See Figure 32
3. Lift cap and remove lead from ground screw. See Figure 33
4. Cut off all motor leads  $\frac{3}{4}$ " down from the connector on the stator side, this way the cap and cord assembly and the connectors can be checked for continuity. See Figures 34 and 35.
5. Remove socket type flat head screws from bearing cap and thread into tapped back-off holes to force cap from housing. See Figure 36.
6. Remove bolts from motor stator housing and lift off casting. **Please Note:** Bearing housing contains two finger spring washers which may fall out of casting when removed. The red and the orange seal failure wires will pull out of hole in stator. See Figure 37.
7. The rotor is now exposed and the red and orange seal failure wires are exposed. Rotor can now be held for removing grinder impeller and pump impeller as described before.
8. To remove upper seal use snap ring pliers and remove snap ring that holds upper seal in place. See Figure 38.
9. After snap ring is removed, bump on end of shaft with plastic hammer to force shaft through upper seal and to push lower ball bearing from housing. See Figure 39.
10. Push old seal out of housing. Clean thoroughly and press in new seal seat as described in the first section steps 8 thru 14.
11. Replace ball bearings if worn or rusted from water being in motor.
12. Use arbor press to push off bearings. Use flat steel bars to get under bearing. See Figure 40.
13. In replacing bearings always press on inner face of bearing.

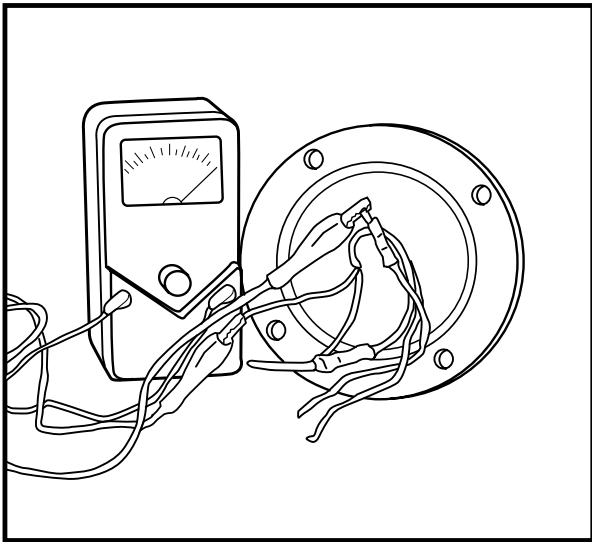

Fig. 35

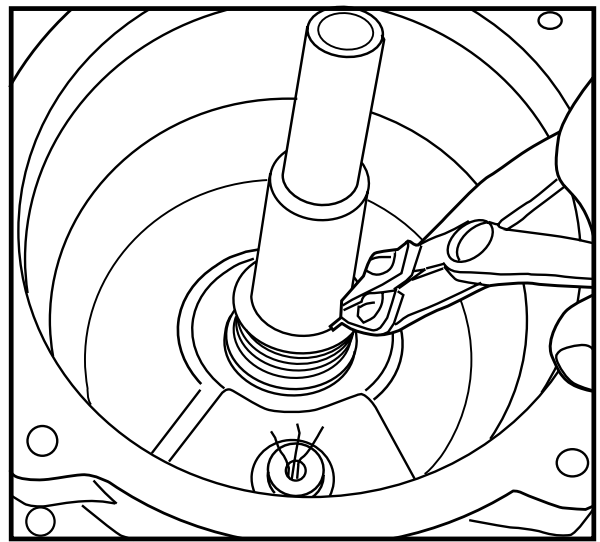

Fig. 38

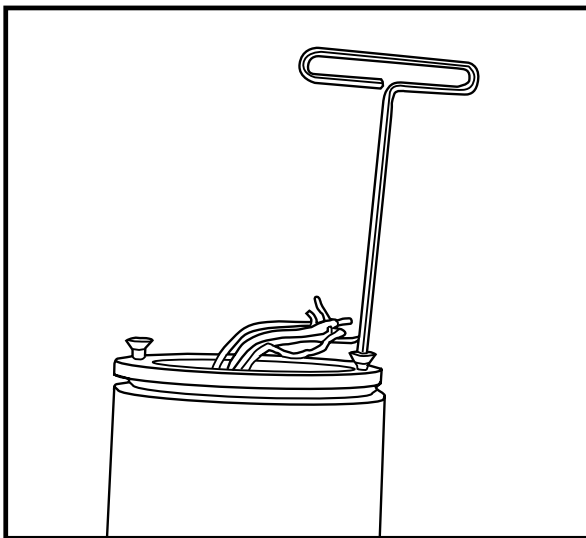

Fig. 36

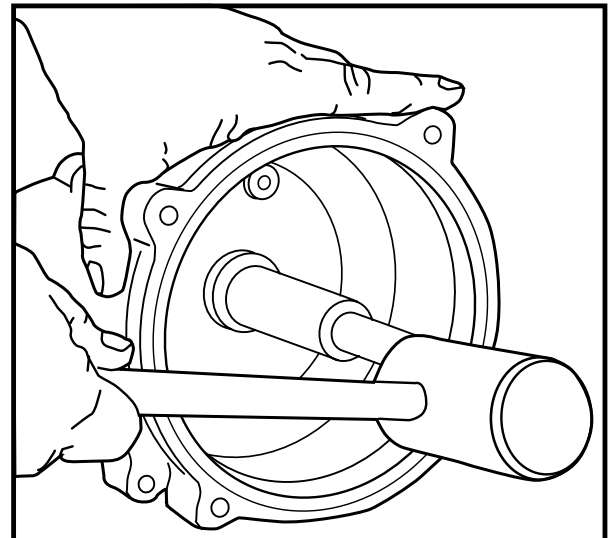

Fig. 39

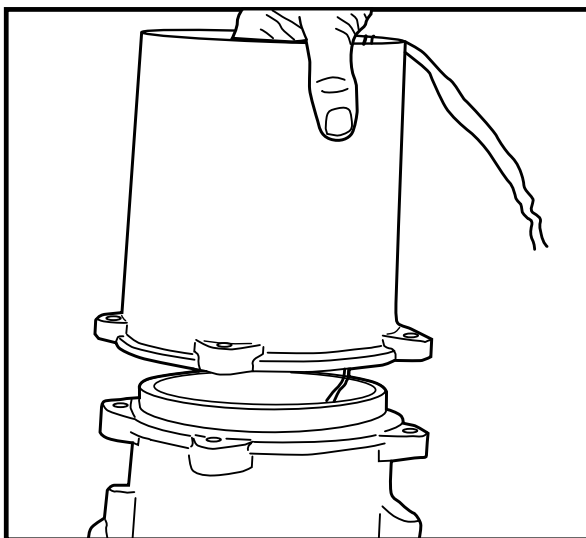

Fig. 37

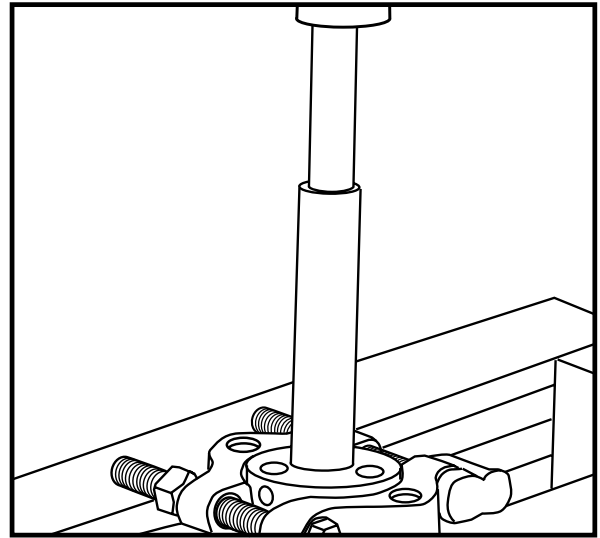

Fig. 40

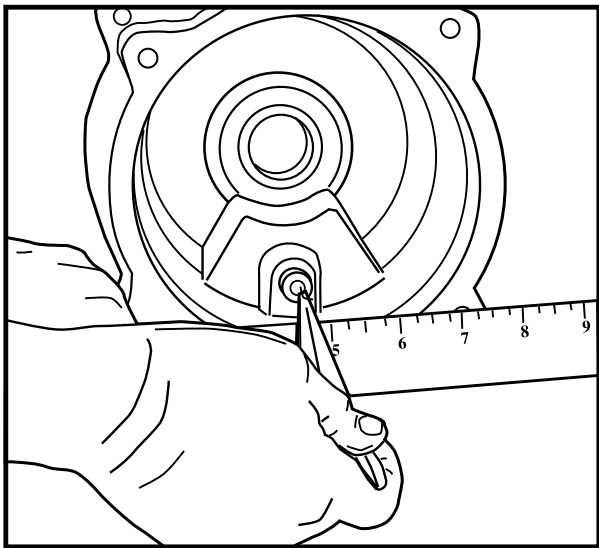

Fig. 41

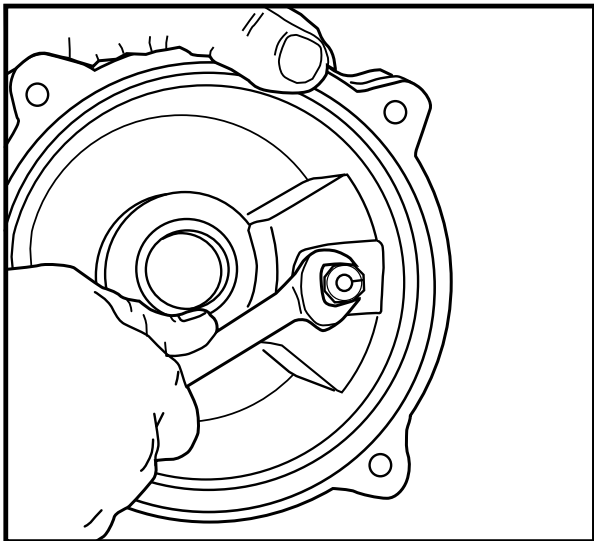

Fig. 42

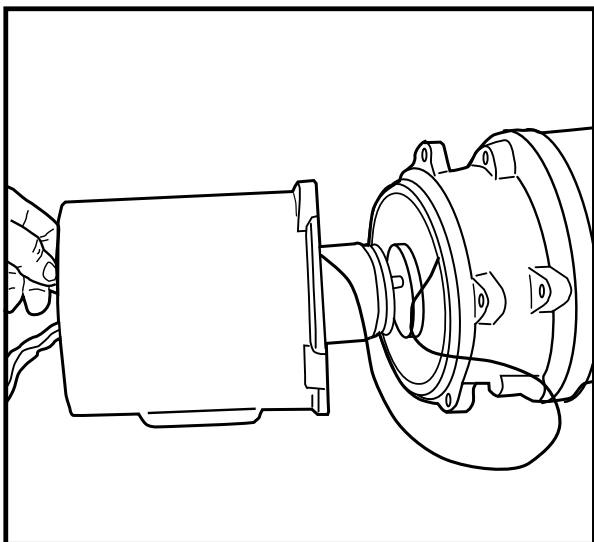

Fig. 43

14. Replace red and orange seal failure wires if necessary. Loosen nut in seal chamber to remove wire.
15. Put in new seal failure wires and adjust so that the probe portion of the seal leak wires are staggered, the end of the longest wire being up  $\frac{1}{4}$ " from the machined face of the casting. See Figure 41. Position shorter lead above the first so probes do not touch. See drawing front cover. Retighten seal nut. Be sure rubber seal ring is in place to seal wire. See Figure 42.
16. Using fine picture hanging wire pull seal failure wire up through stator hole before replacing stator. See Figure 43. The stator is pressed into housing at the factory and is shipped as a unit. Do not try to replace stator in housing in the field, they must be replaced as a unit.
17. Using Allen wrench or small screwdriver in bolt holes to hold parts in place, position upper bearing casting upside-down and run wires down through holes in segmented casting. Next apply STP or equivalent to bearing cup liberally and insert the first finger spring washer flat side down. Apply more STP and insert second finger spring washer flat side down, to make paired finger spring washers. Apply STP again to hold washers in place when casting is turned over and installed on top of rotor. Bearing housing will be held off of stator housing approximately  $\frac{1}{16}$ " and will depress to touch stator housing when pushed downward. See Figures 44, 45 and 46.

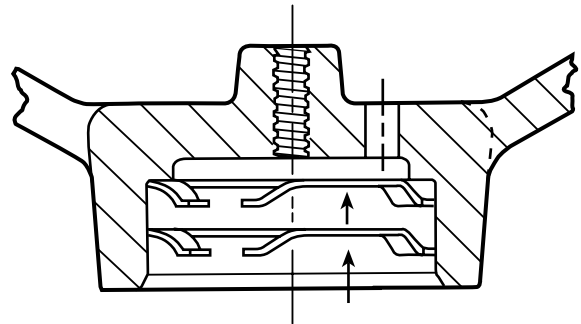

Fig. 4

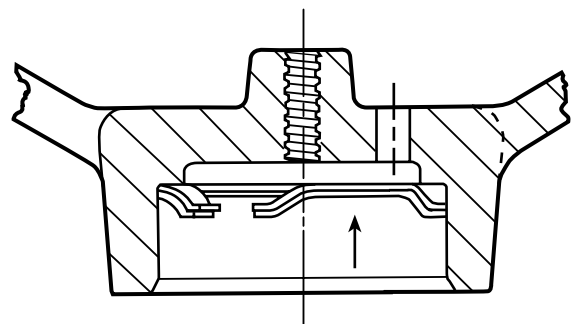

Fig. 5

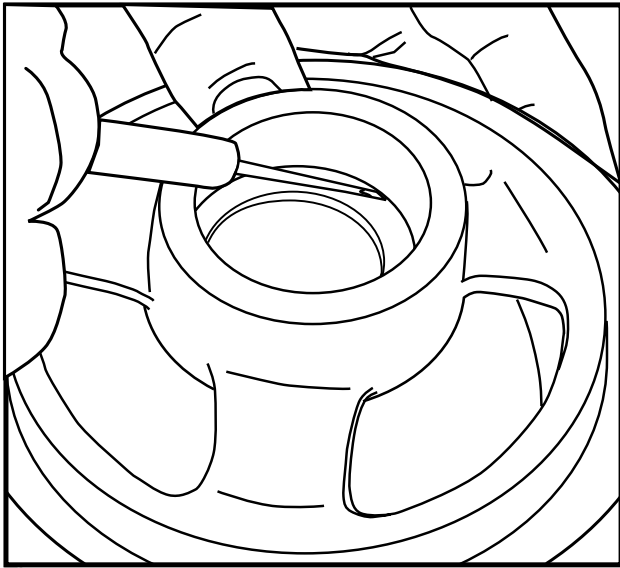

Fig. 46

18. Reassemble all parts as taken apart. BE SURE NEW O-RINGS ARE IN PLACE BEFORE BOLTING PARTS TOGETHER. If necessary to replace cords use cap with cords potted in. In emergency, cut cord can be spliced and taped.

Reconnect all motor lead wires to power cord with pressure type insulated connectors. Crimp tight with crimping pliers that will not penetrate the insulation of the connector.

19. Reinstall cap and cord assembly. Run OHM Meter resistance test at this time to check windings and test for grounding. Test seals with air pressure as described earlier.
20. Fill motor chamber and seal chamber with submersible oil. Fill top motor chamber to bottom of seal plug threads and fill seal chamber to within  $\frac{3}{4}$ " of top of plug fill boss.

**IMPORTANT — AFTER ALL ASSEMBLY AND REPLACEMENT OF PARTS BE SURE PUMP TURNS FREE BY HAND. PUMP MUST NOT BIND IN ANY POSITION OR ROTATION.**

**ELECTRICAL CONTROL BOX** — All instructions and wiring diagrams for connecting pump to control box are included with the control box.

## MOTOR TROUBLE

### CHECK LIST TO DETERMINE MOTOR TROUBLE

#### Checking For Moisture in Motor:

Use ohmmeter and set on highest scale. Readings on the large power cord between any of the conductors red, black, white to green conductor or motor shell should be more than 500,000 ohms. Motor probably will run with a lower reading, but if pump is out of service and reading is below 500,000 ohms the motor housing and stator should be removed and baked in a drying oven at 220°F. to dry out winding. If winding cannot be dried out it must be replaced.

Both motor housing and stator must be replaced as a unit as stator is pressed in at the factory and cannot be removed in the field.

#### Resistance of Windings:

Every motor winding has a fixed resistance and winding must check close to the values given to operate properly. This winding resistance also shows if motor is connected for voltage being used.

Use ohmmeter for this test and set on scale to read directly in ohms.

#### Winding Resistance Values in Ohms

Motor Type & Voltage	Black To White Main Winding	Black To Red Start Winding	White to Red
Single Phase, 230V	1.56	7.84	9.40

#### Full Load Amp Readings for Motors

Motor Type	Volts	Amps	Locked Rotor Amps
Single Phase	230	12	41.0

If amp readings are higher than listed, it indicates voltage may be higher or lower than normal or that pump grinder may be clogged with trash causing extra load on motor.

## TROUBLESHOOTING

### TROUBLE CHECK LIST

Troubles listed below are generally not caused by the pump. Other trouble can occur from faulty control box operation. These will be listed with the control box instructions.

CONDITION	PROBABLE CAUSE
Pump runs but does not pump liquid from basin.	<ol style="list-style-type: none"><li>1. Pump impeller may be air locked, this occasionally occurs on a new installation. Remove pump and clean volute case weep hole and reinstall pump allowing 2 to 3 minutes for air to weep from pump.</li><li>2. Remove pump and guides from wet well, and test in 5 gallon bucket after checking weep hole again. If pump still does not pump, disassemble check valve and check to insure that check valve flapper has not adhered to sealing face. This condition results from assembled basin units setting in the sun before installation. NOTE: Check valve bolts should have Loctite 242 or equivalent applied before reassembly of check valves.</li><li>3. If pump will pump water from bucket, try in wet well again. If it still will not pump, the following problems may exist:<ol style="list-style-type: none"><li>a) Ball Valve - Gate Valve may be in off position.</li><li>b) Discharge piping obstructed</li><li>c) Valve at street or in main line may be off — redundant check valve in backwards.</li><li>d) Tap at force main obstructed — hole not drilled through enough — pipes pushed into tee too far.</li></ol></li><li>4. If pump has been installed for some time and does not pump, it may be clogged at grinder inlet.</li><li>5. Discharge head may be too high. Check elevation. Maximum pump head at zero flow is 105 feet. See pump curve.</li><li>6. If above checks do not locate trouble, motor rotor may be loose on shaft which allows motor to run but will not turn impeller or only at low RPM.</li></ol>
Red light comes on at control box	<ol style="list-style-type: none"><li>1. This indicates some water has leaked past the lower seal and has entered the seal chamber and made contact with the electrode probe. Pump must be removed from basin within approximately two (2) weeks for replacement of lower seal. This preventative repair will save an expensive motor.</li></ol>
Overload trips and alarm buzzer or flashing red light comes on due to high water level in basin	<ol style="list-style-type: none"><li>1. Push in red reset button to reset overload. If overload trips again after short run, pump has some damage and must be removed from basin for checking.</li><li>2. Trouble may be from clogged grinder causing motor to overload or could be from failed motor.</li><li>3. Trouble may be from faulty component in control box. Always check control box before removing pump.</li></ol>
Yellow run light stays on continuously	<ol style="list-style-type: none"><li>1. Indicates H-O-A switch be in the hand position.</li><li>2. Level control switch may have failed causing pump to continue to operate when water is below lower float.</li><li>3. Grinder assembly may be partially clogged causing pump to operate at very reduced capacity.</li><li>4. Check valve may be clogged causing low pump flow. Gate valve or street valve may be in off position.</li><li>5. Pump may be air locked.</li></ol>

---

Circuit breaker trips

1. Reset breaker by pushing clear down on handle then back to "ON" position. If breaker trips again in few seconds it indicates excessive load probably caused by a short in the motor or control box. Check out instructions given with control box before pulling pump.
  2. If this condition happens after an electrical storm, motor or control box may be damaged by lightning.
  3. Resistance reading of the motor with lead wires disconnected from the control box can determine if trouble is in motor or control box.
- 

Pump is noisy and pump rate is low

1. Grinder assembly may be partially clogged with some foreign objects causing noise and overload on the motor.
  2. Grinder impeller may be rubbing on grinder ring due to bent shaft or misalignment.
- 

Grease and solids have accumulated around pump and will not pump out of basin

1. Water shut-off level may be set too high or volume of pumping cycle may be too great allowing solids to settle out of suspension. Set pump shut-off level at the pumps widest part where volute case mates with seal chamber - to 1" below. See Figure 47. Set water level control (float or weight) to following approx. levels:  
2 ft. dia. basin 12" - 14"  
3 ft. dia. basin 6" - 8"  
4 ft. dia. basin 6" - 7"  
above pump shut-off.
  2. Run pump on hand operation for several minutes with small amount of water running into basin to clean out solids and grease. This allows pump to break suction and surge which will break up the solids. If level switch lower weight or float is set properly this condition generally will not occur.
  3. Where all type switches are installed trash may have accumulated around lower weight causing pump to turn off too soon. Clean trash from weight and suspension cable.
- 

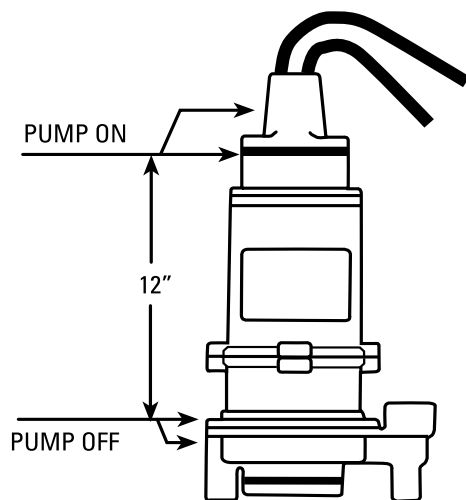
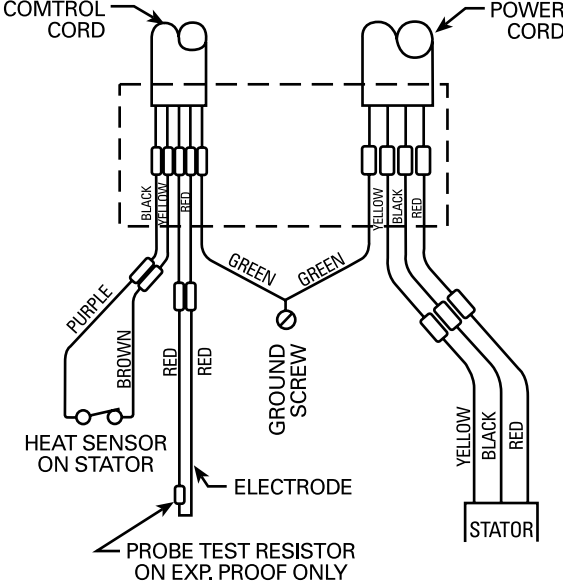

FIGURE  
DIAMETER FOR PUMP CYCLE ON  
24" DIAMETER BASIN

Fig. 47

# MOTOR WIRING DIAGRAM

NOTE: Probe test resistor is used on D2CX20-21 UL explosion-proof only.



## 230 VOLT - SINGLE PHASE

# PUMP DIMENSIONS

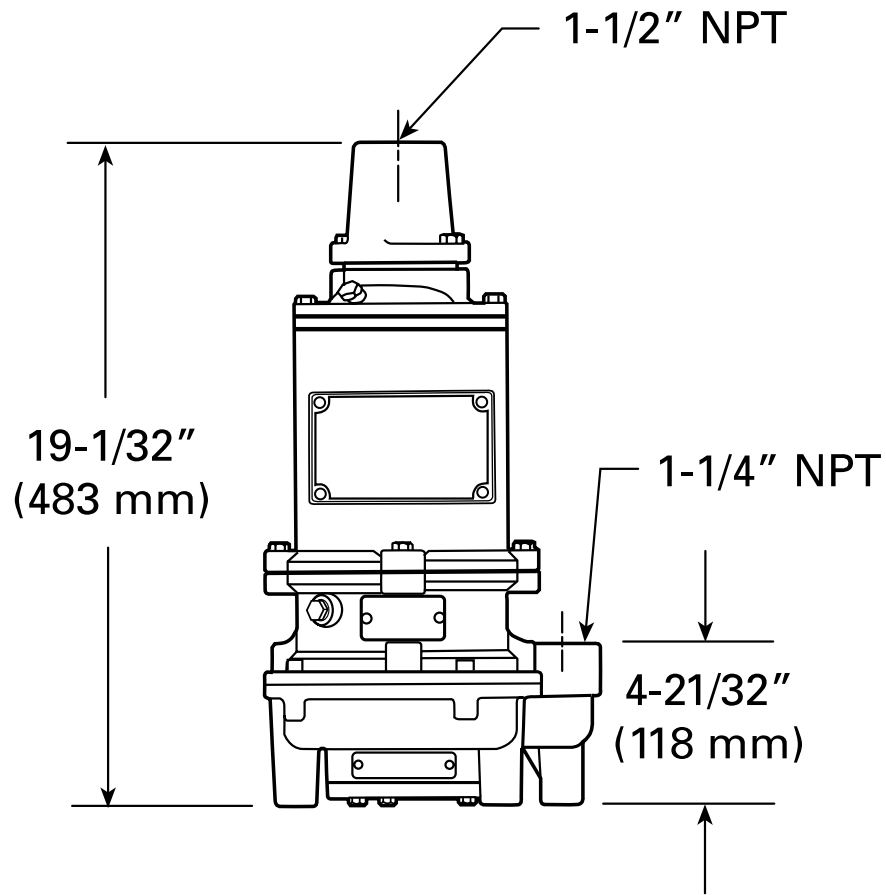
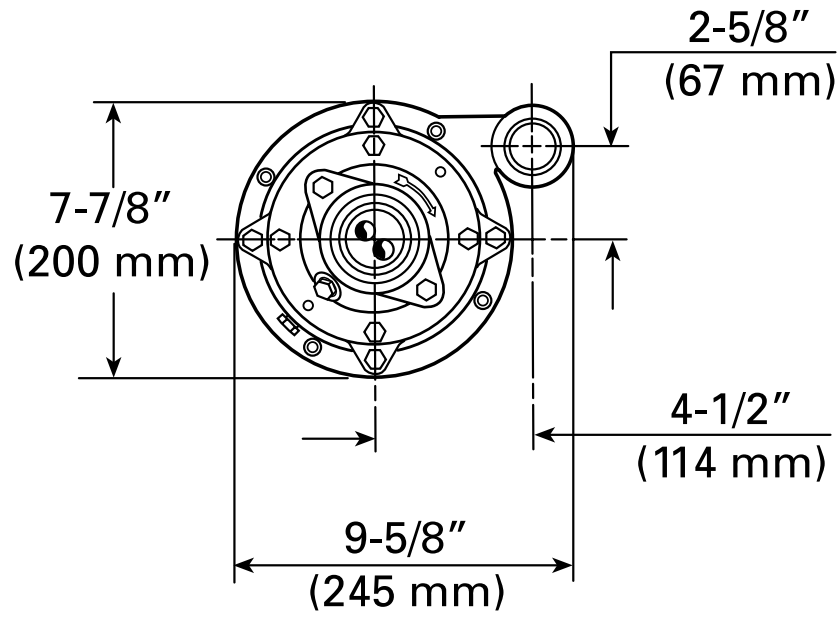

# PERFORMANCE CURVE

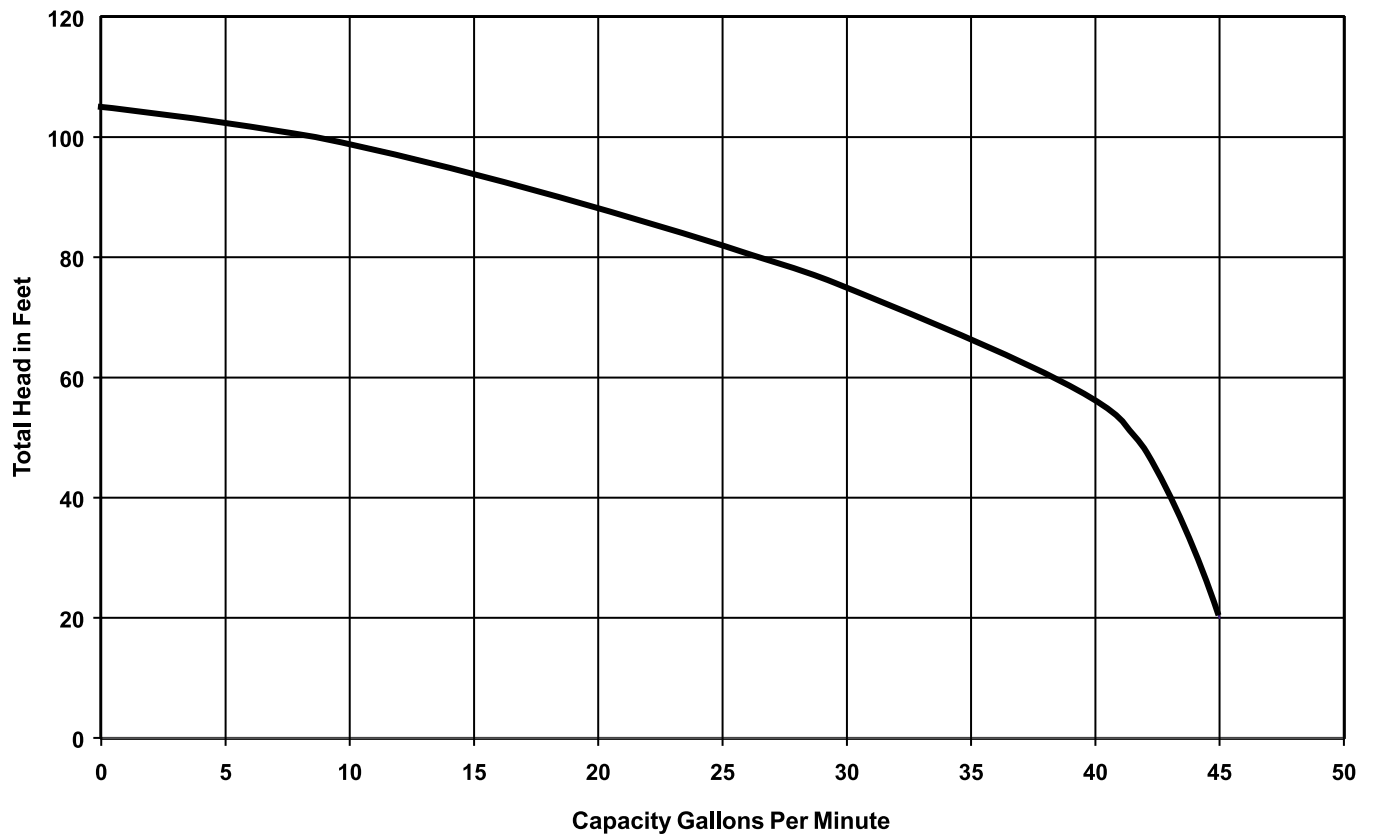

## LIMITED WARRANTY

Delta Environmental Products warrants to the original purchaser of each Delta Environmental Product grinder pump system(s) that any part thereof which proves to be defective in material or workmanship within two year from date of installation or 27 months from manufacture date, (extended warranty available) whichever comes first, will be replaced at no charge with a new or remanufactured part, F.O.B. factory. Purchaser shall assume all responsibility and expense from removal, reinstallation, and freight. Any item(s) designated as manufactured by others shall be covered only by the express warranty of the manufacturer thereof. This warranty does not apply to damage resulting from accident, alteration, design, misuse or abuse. The pump must be installed, operated, and maintained in accordance with the published instructions of the appropriate Installation & Service Manual.

All dual seal grinders must have seal failure and heat sensors attached and functional for Warranty to be in effect. If a seal failure should occur, Delta Environmental Products will cover only the lower seal and labor thereof. Labor based on Authorized Service Center contract allowance. If the heat sensor is not attached and functional, Warranty is void. If the seal failure sensor is not attached and functional, Warranty is void. If the material furnished to the Buyer shall fail to conform to this contract or to any of the terms of this written warranty, Delta Environmental Products shall replace such nonconforming material at the original point of delivery and shall furnish instruction for its disposition. Any transportation charges involved in such disposition shall be for the Buyer's account. The Buyer's exclusive and sole remedy on account or in respect of the furnishing of material that does not conform to this contract or to this written warranty, shall be to secure replacement thereof as aforesaid. Delta Environmental Products shall not in any event be liable for the cost of any labor expended on any such material or for any incidental or consequential damages to anyone by reason of the fact that such material does not conform to this contract or to this written warranty.

ALL IMPLIED WARRANTIES, INCLUDING THE IMPLIED WARRANTY OF MERCHANTABILITY AND THE IMPLIED WARRANTY OF FITNESS FOR A PARTICULAR PURPOSE, ARE DISCLAIMED TO THE SAME EXTENT AS THE EXPRESS WARRANTY CONTAINED HEREIN. Some states do not allow limitations on how long an implied warranty lasts, so the above limitation may not apply to you. MANUFACTURER EXPRESSLY DISCLAIMS AND EXCLUDES ANY LIABILITY FOR CONSEQUENTIAL OR INCIDENTAL DAMAGES FOR BREACH OF ANY EXPRESS OR IMPLIED WARRANTY ARISING IN CONNECTION WITH THIS PRODUCT, INCLUDING WITHOUT LIMITATION, WHETHER IN TORT, NEGLIGENCE, STRICT LIABILITY CONTRACT OR OTHERWISE. Some States do not allow the exclusion or limitation of incidental or consequential damages, so the above limitation or exclusion may not apply to you. This warranty gives you specific legal rights, and you may also have other rights which vary from State to State.