

# DISTRIBUTOR AND HOMEOWNER NOTES

1. The Delta Environmental Products™ Pentair Water Model DF40-M has been tested by NSF International and conforms to ANSI/NSF Standard #40, class 1 effluent requirements. All other DF series models are certified based on provisions in the standard for certification of a series of plants of the same model varying only in rated treatment capacity and materials of construction.
2. State and/or local regulations govern the installation and use of individual Aerobic Wastewater Treatment Systems and must be complied with.

Consult your local Sanitarian/Environmentalist prior to installation.

## HOMEOWNER RECORDS

S/N: \_\_\_\_\_ DATE: \_\_\_\_\_

INSTALLED BY: \_\_\_\_\_

DISTRIBUTOR: \_\_\_\_\_

\_\_\_\_\_

\_\_\_\_\_

\_\_\_\_\_

# NOTICE

This booklet provides operations, installation and warranty information on the **TREATMENT PLANT ONLY**. Other components which you may have, such as dosing equipment, drip irrigation or other components require additional operations booklets and carry separate warranties.

Be sure that you have all of the correct booklets for each of the component pieces in your system.

Contact you installer or call (800) 219-9183.

<b>DELTA ENVIRONMENTAL PRODUCTS™</b>	
<b>PENTAIR WATER</b>	
<b>QUALITY ASSURANCE TAG</b>	
<b>S/N</b> _____	<b>DATE</b> _____
Fiberglass Integrity: Barcol Tested Thickness Verified Clarifier Solid	_____ (Initial)
Water Tested	_____ (Initial)
Metal Integrity: Welds Inspected Paint Adherence Clips/Brackets Intact	_____ (Initial)
Compressor Package Complete: _____	(Initial)
Internal Assembly: Clarifier Intact Air Header Complete & Secured Air Drop Lines Complete & Secured Discharge Tee Assy Center & Level Cover Attached, Sealed & Secured	_____ (Initial)
Component Kit: Air Header Complete & Secured Air Drop Lines Complete & Secured Discharge Tee Assy Secured	_____ (Initial)

Post In A Service/Utility Area

# **WHITEWATER® TREATMENT SYSTEMS**

## **NOTICE**

This home is served by an Individual Wastewater Treatment System. This system will serve you well only if it is properly maintained. Your system is comprised of

---

Your system is located

---

You should not build or fill over this area, or allow heavy traffic. Do not allow water to stand over this area, avoid using strong chemicals, cleaning fluids, etc., which will kill helpful bacteria in the system. You should also avoid flushing grease, food scraps, cigarette butts, sanitary napkins, and other inorganic waste down the drain.

You should have your system serviced (pumped out) every 3 to 5 years. Your service technician can advise you if you need more frequent or additional service.

To have your system serviced, or for additional information, call \_\_\_\_\_ at

---

All of the details regarding system operation can be found in your homeowner's manual which you should have received at installation. If you did not receive a copy call 1-800-219-9183 and we will send you one at no charge.

Keep A Record Of Service Below:

DATE	SERVICE PERFORMED	SERVICE TECHNICIAN

## THE FOLLOWING SHOULD NOT BE USED OR DISPOSED INTO THE SYSTEM

- Greases, Fats and Oils – Pesticides, Herbicides, or any other toxins.
- Garbage disposal should be used sparingly. Dispose of food waste, grease, etc., in the solid waste bin. Food waste represents additional loading the Aerobic Treatment Plant would have to digest, increasing pump out intervals.
- Paints, household chemicals – automobile fluids – do not discard mop water into the system.
- Non-Biodegradable items such as cigarette butts, disposable diapers, feminine hygiene products, condoms, hair, coffee grounds, rags, paper towels, bandages, etc.
- Wash loads must be spread out over the week. Once a week multiple loads or half loads are not recommended.
- Citrus products, oranges, lemons, grapefruit, etc.
- Additives for septic systems – they do no more harm than good.
- Hydraulic overload due to excessive water from other sources.
- Home Brewery Waste – Strong Medicines, Antibiotics. Anti-Bacteria Soaps should be avoided.
- Strong disinfectants or bleaches. Laundry products such as: Lysol, Pine-Sol, Tidy Bowl, or discharge from water softeners, Drano.
- Recommended detergents are: powdered, low-sudsing, low phosphates and biodegradable, washing soda ingredients such as Gain, Arm & Hammer, Fresh Start, and Dash Bright. Fabric softener dryer sheets are recommended.
- Recommended cleaning products are: Non-chlorine, biodegradable and non-toxic such as Ivory & Sunlight dish washing liquids, Cascade & Sunlight powdered dishwasher detergents, Comet & Biz powdered cleaners, baking soda.

**SYSTEMS REQUIRING PUMP OUTS DUE TO THE ABOVE VIOLATIONS ARE NOT COVERED BY THE WARRANTY.**

# **A WORD ABOUT YOUR DELTA AEROBIC WASTEWATER TREATMENT SYSTEM AND HOW IT WORKS**

The Whitewater® Aerobic Wastewater Treatment System that you have purchased produces high quality water suitable for various disposal methods. It is used to enhance your on-site wastewater disposal system. You can be proud that in purchasing your Whitewater® System with a minimum amount of maintenance, you can directly contribute to a cleaner, safer environment.

All wastewater treatment systems of this type work by using the bacteria that nature has provided by pumping air into the system, the bacteria grow and thrive in much larger amounts than would occur naturally. The over-population of bacteria speeds up the process of breaking down domestic wastewater this makes it safe to release into the environment. This entire process takes place within the walls of your specially designed, self-contained Whitewater® Treatment System.

Your Whitewater® System is made up of an outer mixing chamber and center settling chamber. Raw unsettled domestic wastewater enters directly into the mixing chamber. Mixing is accomplished by air passing from the air pump to the air drop-lines located around the outer wall of the mixing chamber. The design is such that solids remain in suspension with a general flow pattern up the outer plant wall, then down the outside of the settling chamber when the air pump is on. This flow pattern allows a quiet condition in the settling chamber.

The mixed liquid enters the hopper-shaped settling chamber at the bottom and travels upward toward the discharge pipe. The quiet condition allows solids to settle down and re-enter the mixing chamber.

The result of this process is a clear, odorless discharge, which meets or exceeds state water quality standards.

By following the few simple steps that you find in this manual, your Whitewater® System will provide you with years of service and the knowledge that you are doing your part to protect our ground water, lakes, rivers, and streams.

Whitewater® is a registered trademark of Delta Environmental Products™ a Pentair Water Company

# HOMEOWNER CARE AND OPERATION INSTRUCTIONS

The Whitewater® System has been designed and built to provide long term, reliable and efficient service.

Once the unit has been installed, (see installation instructions) the unit will operate with a minimum amount of attention.

Please reference the system's Data Plates that are located on aerobic tank 24" cover, air pump, and the alarm panel in the event that a problem arises or service is required.

The following should be accomplished as checks for system failure:

Daily - Observe the warning device, which comes on when the power to the air pump has been interrupted or when the air supply system has malfunctioned. If the alarm is activated, check for a blown fuse or thrown circuit breaker. Check air pump to be sure it is operating. Once accustomed to the soft humming sound of a properly operating unit, any unusual noise is an indication of malfunction. If an unusual noise is detected or total failure is observed, call your local dealer for service.

Weekly - Check the treatment plant for offensive odor. If such a condition should develop, call service.

Every  
3 Months - **The air filter on the air pump should be cleaned.** Rinse with warm water if necessary. (See installation instructions). Do not use oil or other solvents.

Every  
6 Months - Inspect and make any necessary adjustments to mechanical and electrical components.

- Inspect effluent quality's color, turbidity and check for any odor.
- Take a sample from the aeration tank and perform a 30 minute settle ability test described in the "Solids Removal" section.
- Break up any sludge that may have developed in the clarifier so it can return back to the aeration zone. Care should be taken to prevent solids from leaving the unit.
- **The homeowner must be notified in writing if any improper operation is observed and can not be corrected at the time of service.**

Note - To keep maintenance to a minimum and ensure high effluent quality, the following items should not be permitted to enter the system.

## ITEMS NOT PERMITTED IN THE SYSTEM

- Strong disinfectants or bleaches, other than small amounts normally utilized in day to day cleaning and laundry (be conservative). Laundry detergents recommended for use are low-sudsing, low phosphates and biodegradable, such as Gain, Arm & Hammer, All, Fresh Start, Dash Bright.
- Discharge from water softener
- Any type of oils, greases, or other chemical wastes
- Disposable baby diapers and wipes
- Sanitary napkins, condoms or other similar items
- Hair, bandages, rags, or string
- Latex, plastic, or metallic objects
- Coffee grounds or cigarette butts
- Mud or sticks
- Paper towels, napkins, or Kleenex
- Tidy Bowl type products
- Beer waste or any other rich liquids
- Garbage disposal should be used sparingly, not as a method of disposing all solid food waste. In order to ensure good plant operation, waste should be disposed of in the garbage container.

**The Whitewater® System is designed to handle domestic wastewater and nothing else should go into it. For anything other than domestic wastewater contact: Delta Environmental Products™ a Pentair Water Company**

# WARNINGS

1. The proper operation of this or any other home sewage system depends upon proper organic loading and the life of the microorganisms inside the system. Delta is not responsible for the in-field operation of a system, other than the mechanical and structural workings of the plant itself. We cannot control the amount of harsh chemicals or other harmful substances that may be discharged into the system by the occupants of a house hold we can only provide a comprehensive owner's manual that outlines substances that should be kept out of the system.
2. Hydraulic overloading (flows in excess of design flow) may cause the sewage treatment system not to perform to the fullest capabilities.
3. Ants have been shown to be destructive to the air pump. Regular care should be taken to prevent infestation of ants near the system. Damage or destruction by ants is not covered under manufacturer's warranty.
4. Your State or Local Health department may require other pieces of equipment to function separately or in conjunction with equipment manufactured by Delta Environmental Products™. Delta Environmental Products™ is not responsible for the mechanical or electrical safety of equipment it does not manufacture or supply with its aerobic treatment units. Particular care should be used in evaluating the electrical or mechanical safety of equipment manufactured by others. This may include but not be limited to electrical control panels or air pumps.
5. If electrical service has not been installed for checking air distribution system during installation, and if an extension cord is used to test the air pump, never leave the extension cord plugged in. Remove it after testing is completed.
6. Due to a possible fire hazard, DO NOT plug into service equipment on power pole and DO NOT use extension cords. All electrical work performed by the installer or others must be in accordance with the National Electrical Code and Local Codes.
7. The operation & maintenance outlined in this manual applies to normal operating conditions. Extreme conditions such as frigid cold temperature, extreme heat and high altitudes may effect the operation and maintenance of this unit. Consult Factory regarding these extreme conditions.

## **WARNING**

**Failure to Properly Secure the  
Top May Result in a Serious  
Health or Safety Hazard.**

# SOLIDS REMOVAL

The **Whitewater<sup>®</sup> Treatment System** is designed to provide years of trouble free operation.

Determination of the need for solids removal can be done through a simple test. A one quart sample should be pulled from the aeration tank and can be done so through the 4" sample port. Allow the sample to settle in a clear one quart jar for thirty minutes. If the solids content exceeds 60% of the total volume after settling, the treatment plant should be pumped out. Call your local authorized sewage disposal service to have the tank contents pumped out and disposed of properly.

The method of pumping out should be as follows:

- Remove any floating solids by skimming.
- The air pump must be operating to keep the solids in suspension.
- Pump out two thirds of the tank volume with the suction pipe opening being placed at the tank bottom.

After the pump-out process is complete, fill the tank with fresh water to normal operating level.

Refer to the Installation Instructions to get the treatment plant back into operation.

Should indication of improper operation be observed at any point in time, contact your local distributor.

**NOTE: THE COST ASSOCIATED WITH PUMPING THE TREATMENT SYSTEM IS NOT COVERED UNDER WARRANTY AND IS NOT INCLUDED IN THE SERVICE POLICY.**

# SEASONAL USE GUIDELINES OF WHITEWATER AEROBIC TREATMENT UNIT

These guidelines are for conditions as outlined below and apply for systems that are not in use for periods of time indicated. Site conditions not covered by the following must be forwarded to Delta for recommended guidelines to meet the particular site conditions.

1. System not in use for more than one month and less than three months. Electrical power is left on and there are no frost conditions.
  - Leave air pump on and system running.
2. System not in use more than three months. Electrical power is turned off and there are not frost conditions.
  - While system is operating with the air pump on, remove all material and liquid from tank.
  - Refill with clean water.
  - Turn off air pump.
3. System not in use more than three months. Electrical power is on and there are not frost conditions.
  - Leave air pump on and system running.
  - OR, while system is operating with the air pump on, remove all material and liquid from tank.
  - Refill with clean water.
  - Turn off air pump.
4. System not in use. Electrical power is turned off and there are frost conditions.
  - While system is operating with the air pump on, remove all material and liquid from tank.
  - Turn off air pump.
  - If high ground water is present, fill with clean water.
  - If no ground water is present, leave tank empty.

***UNDER NO CIRCUMSTANCES SHOULD THE AIR PUMP BE TURNED OFF FOR MORE THAN A FEW DAYS WITHOUT REMOVING TANK CONTENTS!!***

# SAMPLING REQUIREMENTS

A Whitewater® aerobic treatment plant properly operated and maintained should provide the following effluent quality of:

Carbonaceous Biochemical Oxygen Demand 5 day average (CBOD <sub>5</sub> ) of	less than 25 mg/l (or ppm),
Suspended Solids (SS) of	less than 30 mg/l (or ppm),
Volatile Suspended Solids of	less than 30 mg/l (or ppm).
pH of	6.0 to 9.0
Dissolved Oxygen	1.5 to 3.0 mg/l (or ppm)

## Taking Effluent Samples:

Samples must be taken in the effluent discharge line or an effluent pump or after the chlorine contact tank. We recommend allowing the effluent to flow through the discharge pipe for a minimum of 2 minutes before taking the sample. This will allow any solids to be flushed out that might have accumulated in the discharge pipe. Please find attached drawing of a Sample Port.

**SAMPLING SHOULD BE TAKEN BY A LOCAL CERTIFIED TESTING LABORATORY OR BY FOLLOWING THEIR PROCEDURES. THE FOLLOWING RECOMMENDED GUIDELINES MAY BE USED IF LOCAL PROCEDURES ARE NOT AVAILABLE.**

### 1. Carbonaceous Biochemical Oxygen Demand (CBOD)

Samples for CBOD analysis may degrade significantly during storage between collection and analysis, resulting in low CBOD values. Minimize reduction of CBOD by analyzing the sample promptly or by cooling it to near-freezing temperature during storage. However, even at low temperature, keep the holding-time to a minimum. Warm the chilled samples to 20°C before analysis; some storage time can be used to accomplish this conveniently.

- a. Grab Samples: If analysis is begun within 2 hours of collection, cooling is unnecessary. If analysis is not started within 2 hours of sample collection, keep sample at or below 4°C from the time of collection. Begin analysis within 6 hours of collection; when this is not possible because the sampling site is distant from the laboratory, store at or below 4°C and report length and temperature of storage to the Lab. In no case, start analysis more than 24 hour after grab sample collection. When samples are to be used for regulatory purposes, make every effort to deliver samples for analysis within 6 hours of collection.

2. Total Suspended Solids (TSS)

Use resistant-glass or plastic bottles, provided that the material in suspension does not adhere to container walls. Begin analysis as soon as possible because of the impracticality of preserving the sample. Refrigerate sample at 4°C to minimize microbiological decomposition of solids.

3. Phosphorous

If phosphorus forms are to be differentiated, filter samples immediately after collection. Preserve by freezing at or below -10°C. Add 40 mg HgCl<sub>2</sub>/L to the samples, especially when they are to be stored for long periods. Do not add either acid or 2CHCl<sub>3</sub> as a preservative when phosphorus forms are to be determined. If total phosphorus alone is to be determined, add 1 mL concentration HCL or freeze without any additions.

Do not store samples containing low concentrations of phosphorus in plastic bottles unless kept in a frozen state because phosphates may be adsorbed onto the walls of plastic bottles.

Rinse all glass containers with hot diluted HCL, then rinse several times in distilled water. Never use commercial detergents containing phosphate for cleaning glassware used in phosphate analysis.

4. Ammonia Nitrogen

Most reliable results are obtained on fresh samples. Destroy residual chlorine immediately after sample collection to prevent its reaction with ammonia. If prompt analysis is impossible, preserve samples with 0.8 mL concentration H<sub>2</sub>SO<sub>4</sub>/L sample and store at 4°C. The pH of the acid-preserved samples should be between 1.5 and 2. Some wastewater may require more concentration H<sub>2</sub>SO<sub>4</sub> to achieve this pH. If acid preservation is used, neutralize samples with NaOH or KOH immediately before making the determination.

## SAMPLE PROCEDURES:

1. PRIOR TO TAKING SAMPLE HAVE WHITEWATER PLANT DISCHARGE EFFLUENT FOR UP TO 4 MINUTES BY FLUSHING TOILETS AND/OR USE GARDEN HOSE TO FLUSH OUT SAMPLE PORT.
2. INSERT SAMPLE COLLECTING BOTTLE TO COLLECT ONLY EFFLUENT WHICH IS CASCADING OVER THE CASCADING EDGE.
3. HANDLE, STORE, AND TRANSPORT SAMPLES AS SPECIFIED BY POLICIES AND PROCEDURES PROVIDED BY THE TESTING LABORATORIES.

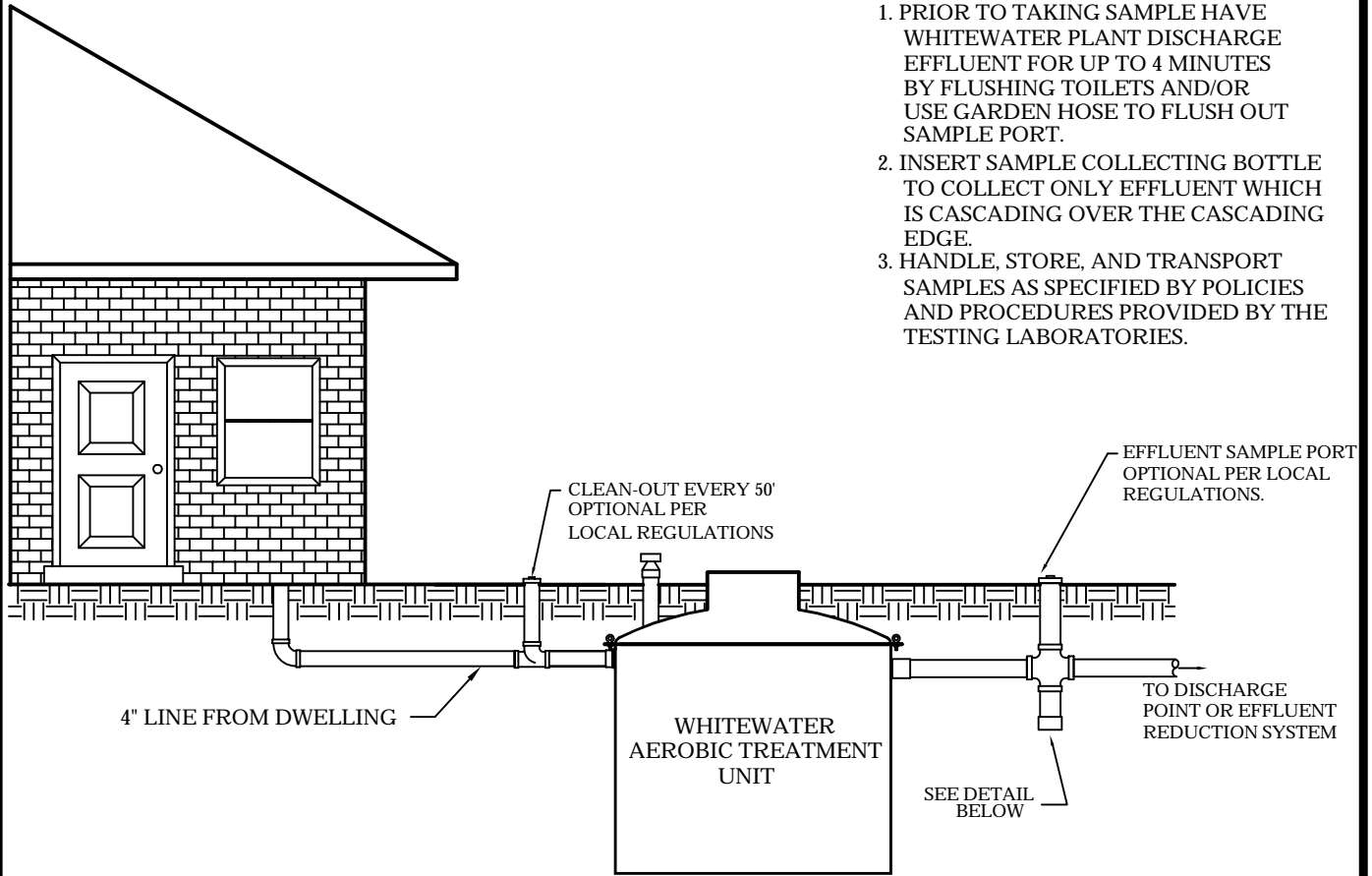

## EXAMPLES OF SAMPLE PORTS

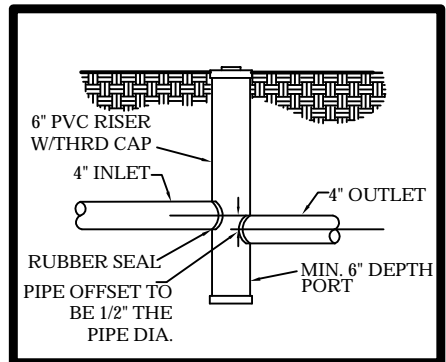
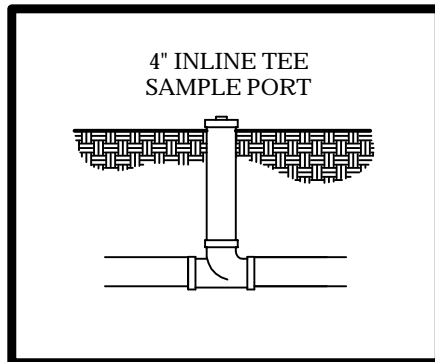
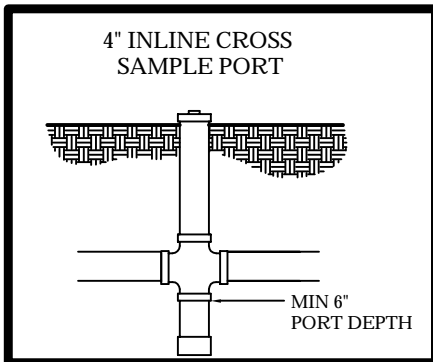

DELTA ENVIRONMENTAL PRODUCTS  
P. O. BOX 969 DENHAM SPRINGS, LA 70727

## SAMPLE PORTS

DWN BY:  
B.LANDRY

DATE:  
06/24/03

SCALE:  
N.T.S.

DWG. NO.:  
CRT361

# INSTALLATION INSTRUCTIONS

## ONLY FOR USE BY CERTIFIED, LICENSED INSTALLER

1. Prepare an excavation, having a diameter approximately one foot larger than the tank and a depth that will allow approximately 3 inches of the inspection port to extend above normal ground level. Backfill with a 6 inch layer of sand or gravel if otherwise unable to provide a smooth, level, compact base. We recommend that the hole be roped off in some fashion to prevent injury to passersby.
2. Utilizing lifting lugs provided, place the plant in the excavation so that the inlet and outlet line up with the sewer piping. The inlet line should slope down toward the plant and the outlet line should slope down away from the plant. The plant should be level within 1/2 inch, edge to edge.
3. Position inlet and outlet lines and make connections as necessary, depending upon the construction materials. The inlet line should be inserted and glued into the inlet elbow and the discharge line should be inserted and glued into the outlet coupling. Note: Open inspection port and make sure discharge tee assembly is level and centered in clarifier prior to attaching discharge piping. Fill the tank with water until water flows from the discharge before backfilling. Back fill around the treatment plant up to the bottom of the discharge connections.
4. Do not install the air pump(s) in a low lying area where water may accumulate. The air pump should be installed near the control panel and within 100 ft. of the tank. Air pump can be installed outdoors or in a clean, well ventilated area, such as a tool room, garage, etc. **If the linear air pump is to be installed in an additional enclosure, the enclosure must be approved by Delta in writing.**
5. Mount the control panel in an area such that the alarm can be heard and be readily observed. A 3-wire grounded GFI circuit, are required for safety. Install a disconnect switch near the panel to visually disconnect the control panel from the power source. All electrical work shall be done according to NEC and local code requirements. The control panel must be grounded. Connect the source ground wire to the ground location in the panel.
6. The control panel is rated for indoor and outdoor use and contains a fuse for the air pump. An electrical malfunction in the air pump or wiring to the air pump will cause the fuse to blow. The control panel also contains a pressure switch with a visual and audible alarm. Loss of air pressure caused by air pump system malfunction or a high water level in the treatment plant will cause the alarm to sound and light to illuminate.

7. Attach control panel to suitable mounting surface using all four mounting holes on back of box. Use proper screws of sufficient length to insure a secure and permanent mounting.
8. Control panel is rated for outdoor service, however, do not place it where it can be immersed in rising water or where run-off water such as from a roof will fall on it. Do not mount it where it is subject to wetting from sprinklers, hoses, etc.
9. The control panel must never be connected to a circuit that is not properly grounded. Never connect the unit to a non-grounded circuit. If there is doubt, have a qualified electrician check for proper grounding. The control panel must be connected to a 20 amp maximum electric source equipped with a ground fault interrupter (GFI) circuit breaker. A standard circuit breaker can be replaced with a GFI circuit breaker which can be obtained from almost any store that sells electrical supplies.
10. After the control panel is properly mounted, connect conduit and install wiring as shown on drawings bound herein.
- 11A. Install the float switch wire from the control panel to the treatment plant. Wire can be direct burial type UF 600 volt or can be installed in schedule 40 pvc conduit. Use type THWN, 600 volt if installed in conduit. Wire must be buried in accordance with NEC table 300-5. If in doubt, bury 24" deep. Keep sufficient distance or depth from air line to avoid confusion of pipes or damage to wiring during installation or repair of air piping. Connect to the float switch normally open contacts using underground rated compound filled wire nuts.
- 11B. If using the CP22 panel ignore 11A. To set the high level pressure switch that detects high water level in the unit follow the below instructions:

Bring plant to operating water level with compressor turned on. Using properly sized screw driver, turn high level alarm adjustment screw clockwise until alarm occurs. Then turn the screw counter-clockwise until alarm stops.  
(See "high level pressure setting" drawing in this manual.)
12. Connect the pressure air tubing to the 1/8" barb-fitting directly to the 3/4" airline or directly to the compressor. Refer to illustrations in Appendix B for appropriate air tubing connections.
13. Install 3/4" schedule 40 PVC piping between air pump and treatment unit. A minimum of 12" ground cover is recommended.

14. Turn power on to control panel. Air pump should start.
15. Check air piping joints for leakage using a soapy water solution. Repair if necessary and then carefully backfill air line and inlet and discharge piping and cover plant to grade level.
16. Re-check water level in the tank.
17. Plant is ready to receive incoming sewage. No special start-up procedures are required. The process is naturally occurring and does not require any special additives.
18. Test alarm circuit by momentarily squeezing air tubing and allowing air pressure to decrease. This should take a few minutes. Alarm should occur. Release air tubing and alarm should stop. Lift float in tank to horizontal position. Alarm should occur. Release float. Alarm should stop. The audible alarm can be turned off by flipping the toggle switch on the panel front door to the left.
19. Close cover on control panel and lock if necessary.
20. In the event that a fuse blows, replace with time delay or slow blow, 125 volt minimum voltage rating and the same amp rating as the existing fuse.
21. The distribution of air to all droplines must be uniform. If the air flow is not evenly distributed, check the air pump or the main air line.
22. Spend time with your customer whenever possible. Review operation instructions. Be sure that the customer has a manual to keep. This saves valuable time avoiding return visits.
23. Retain these instructions for future reference.
24. **WARNING:** Control panel contains high voltage and must only be installed and serviced by qualified personnel.
25. **WARNING:** DF series fiberglass construction is furnished with a 24" polyethylene cover with gasket that is securely fastened to the tank lid. The cover must be placed six inches above grade to prevent surface runoff.
26. **WARNING:** DF series concrete construction is furnished with a 20" Poly-lok riser and a cover. Risers are cast into the concrete lid to ensure water tightness. The covers have gaskets and are designed for self sealing. The cover must be placed six inches above grade to prevent surface runoff.

# DELTA ENVIRONMENTAL PRODUCTS RECOMMENDED INSTALLATION PROCEDURE

## **1. EXCAVATION:**

Dig hole from the side for accurate sizing. This reduces the bridging distance between the tank and undisturbed soil and provides good support for inlet and outlet pipes. The bottom of the hole should be undisturbed and level. If leveling is necessary due to over excavation, use sand for fill.

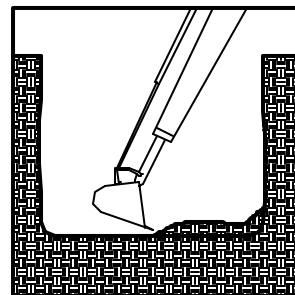

**NOTE:** Never place tank directly on rock. place at least six inches of sand or gravel bedding between the tank and rock surface.

## **2. TANK PLACEMENT:**

Use the back hoe to set the tank. Lifting lugs are furnished to lift the tank.

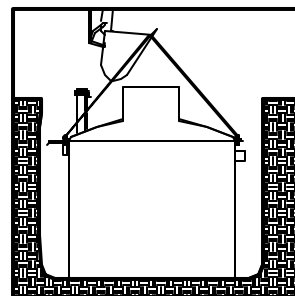

**CAUTION:** A small amount of soil or sand should be used around the bottom of the tank to hold it in place. Sand is best. If excavated soil is used, tamp it underneath the tank to provide a good base.

## **3. FILL TANK WITH WATER:**

Place hose in six inch riser. Begin filling tank with water.

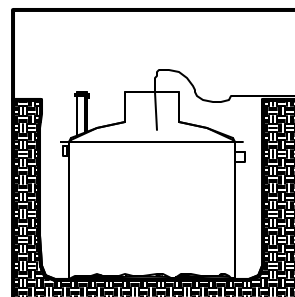

DELTA ENVIRONMENTAL PRODUCTS  
P. O. BOX 969 DENHAM SPRINGS, LA 70727

## INSTALLATION PROCEDURE

DWN BY:  
B.LANDRY

DATE:  
06/23/03

SCALE:  
N.T.S.

DWG. NO.:  
DEP034-A

#### **4. GFI CONTROLS AND AIR PUMP**

Install duplex or quadruple GFI or GFI protected receptacles at the selected location of the air pump. Mount control panel and install fittings, tubing and piping to tank location.

**CAUTION:** Do not plug anything but the air pump into the control panel.

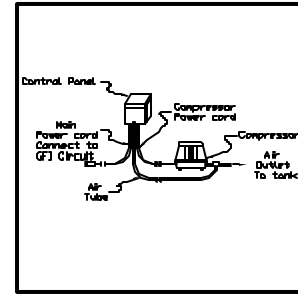

#### **5. INLET/OUTLET AND AIR CONNECTIONS**

Properly make solvent cemented inlet, outlet and air connections.

#### **6. FILLING THE TANK**

Finish filling tank with water until it drains out of outlet. Begin backfilling with natural soil or a good back fill material.

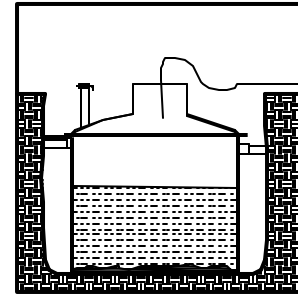

#### **7. AIR DISTRIBUTION**

Turn the air pump on and check all air connections and piping for air tightness. Observe air/water mixture through 4" riser.

**NOTE:** If electrical GFI receptacle has not been installed, for checking air distribution system during installation. Use an extension cord to run the air pump. Never leave the extension cord plugged in. Remove it after inspection is completed.

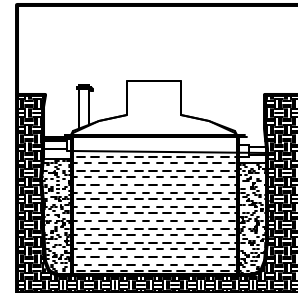

**WARNING :** Possible Fire Hazard

Do Not plug into main service equipment on power pole.

Do Not use extension cords

#### **8. FINAL BACK FILLING**

Back fill Should be mounded above grade slightly to allow for settling. Tamp the back fill beneath the inlet, outlet and air piping to provide good support.

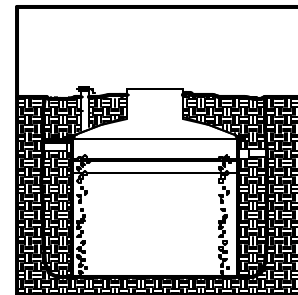

DELTA ENVIRONMENTAL PRODUCTS  
P. O. BOX 969 DENHAM SPRINGS, LA 70727

## INSTALLATION PROCEDURE

DWN BY:  
B.LANDRY

DATE:  
06/23/03

SCALE:  
N.T.S.

DWG. NO.:  
DEP034

## 9. TRIM INSPECTION RISERS

Trim inspection risers to proper length. The 4" aeration inspection riser also serves as a vent for the tank.

**Caution:** The bottom of the 4" aeration riser must be above the water level for both visual inspection and ventilation. Both of the optional 6" and 4" top caps must be above ground level to prevent ground water from entering the risers.

**Caution:** Care must be taken not to push the optional 6" Clarifier Inspection Riser down too far. This may cause damage to the effluent discharge tee assembly and the clarifier.

**Caution: Maximum burial depth - 2 feet from top of tank flange with dome or 24" manways and 1 foot from top of tank flange with flat lids. For burial depths beyond 2 feet contact the factory.**

**For further details refer to the installation manual**

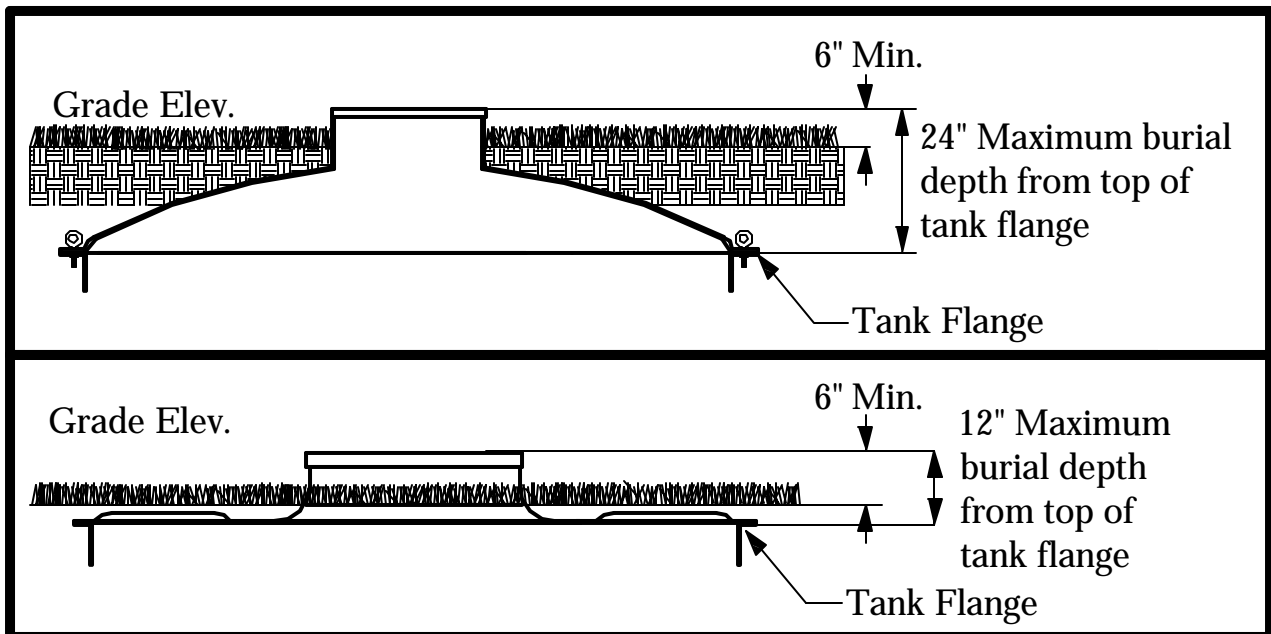
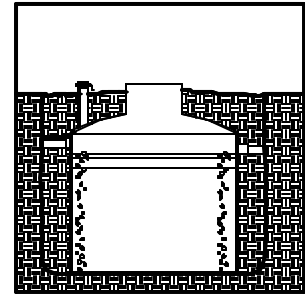

DELTA ENVIRONMENTAL PRODUCTS  
P. O. BOX 969 DENHAM SPRINGS, LA 70727

## INSTALLATION PROCEDURE

DWN BY:  
B.LANDRY

DATE:  
06/23/03

SCALE:  
N.T.S.

DWG. NO.:  
DEP034

## DELTA ENVIRONMENTAL PRODUCTS PUMP OUT PROCEDURE

**1.** Determine the amount of MLSS by using a "Sludge Judge" type sampler through the 4" vent/sample port riser.

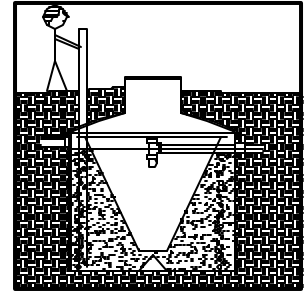

**2.** Leave the air compressor for the ATU running.

**3.** Insert vacuum hose into the main access riser. Skim off any floatable solids on the surface of the clarifier and lower to the bottom of the clarifier.

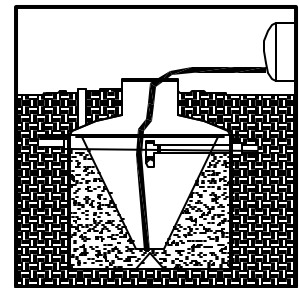

**Caution:** Care must be taken not to damage the discharge tee assembly.

**4.** Pump out 80 to 90 percent of the ATU. Then remove the vacuum hose.

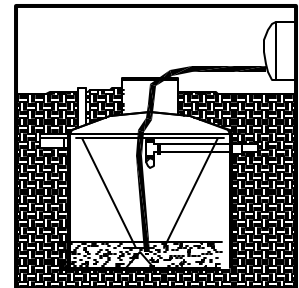

**5.** Insert a water hose into the main access riser. Wash down the clarifier walls and partially refill the ATU with clean water.

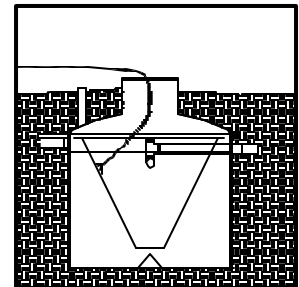

**6.** Repeat step 3 and refill the ATU with clean water.

\*Never leave tank empty.

\*Always use licensed pumpers/haulers for this task.



DELTA ENVIRONMENTAL PRODUCTS  
P. O. BOX 969 DENHAM SPRINGS, LA 70727

## PUMP OUT PROCEDURE

DWN BY:  
B.LANDRY

DATE:  
04/09/03

SCALE:  
N.T.S.

DWG. NO.:  
DEP033

# TROUBLE SHOOTING GUIDE FOR DELTA WHITEWATER AEROBIC TREATMENT UNITS

## AIR SUPPLY MALFUNCTION

1. Check to be sure all airdrops are working properly. They should be bubbling evenly and forcefully. A septic (rotten egg) odor could mean that the system is not getting enough air. If the air drops are not working, partially working or working very little (slight bubbles), check the following:
  - a. Check to be sure the air pump is working.
    - check timer if one is used
    - bypass timer/temporarily connect directly to source
    - check the electrical source
    - if electrical source is ok-check service guide for pump unit troubleshooting information
    - wash air filter on pump
    - consult manufacturer for servicing information
  - b. Check to be sure tank is not severely out of level. Air follows a path of least resistance. The pressure differences at the bottom of drop lines can be enough to prevent or restrict air flow.
  - c. Check for broken or cracked air lines both outside and inside the tank.
  - d. Ants will destroy an air pump. Check to see if there is an ant nest around the air pump.
  - e. Air pump should be protected from rising water.
  - f. Always check to see if inlet and outlet lines are correctly installed.

## **INTERNAL ASSEMBLY MALFUNCTION**

1. Raw, untreated sewage from the aeration chamber (bubble zone) should not enter the clarifier (quiet zone) because of improperly installed or loose seals or gaskets where pipe goes through the clarifier wall. Check the size of holes to be sure that there is no clearance for matter to pass through the wall around the piping.
2. Check to be sure all internal piping and connections are tight.

## **DESIGN OVERLOAD**

1. The system could be hydraulically overloaded (there is too much water going through the system for the size of the system).
2. The system could be biologically overloaded (there is too much waste for the size of the system).

## **IMPROPER INSTALLATION OR SETTLING**

1. You should follow the manufacturer's installation procedures very carefully.
2. Where settling is common, approximately 2" of sand should be placed and tamped in the bottom of the hole.
3. Proper installation is the first step in preventing call backs for service problems.
4. Whenever possible, it is important to spend time with the homeowner. Be sure they have an operations book. A few minutes invested in the beginning will avoid service calls later.

## **NO HARSH CHEMICALS SHOULD BE PUT INTO THE SYSTEM**

1. Water in the aeration chamber (bubble zone) should be the color of chocolate milk. Blue or gray/blue water indicates heavy use of detergents or other chemicals. If water appears sudsy there is too much detergent being used.
7. Water in the clarifier (quiet zone) should be clear but scum and debris may appear on the surface. Water is discharged into the discharge tee at a minimum of 6-8 inches below water surface. You MAY not be able to see clear water by looking into the tank. Samples must be taken at the sample port.
8. Oils and grease should be kept to a minimum. Grease tends to form in white balls.

# TROUBLE SHOOTING ELECTRICAL SYSTEM

1. Air pump does not run:
  - a. Check main service for power.
  - b. Check and/or replace fuse with same rating as is in control panel.
  
2. Alarm does not occur when air pump is off:
  - a. Malfunctioning pressure switch - replace.
  - b. Malfunctioning light or buzzer - replace.
  
3. Alarm occurs continuously even when air pump is running
  - a. Air leak in main air system or air tubing to pressure switch - repair leak or replace air line.
  - b. Malfunctioning pressure switch - replace.
  - c. High water level in tank - inspect for cause.
  - d. Short in float switch wire or float switches - repair or replace.

**NOTE:** All replacement parts are available from your local dealer.

**CAUTION:** Electrical shock or hazard may occur if unit is not serviced properly. The manufacturer recommends that a licensed electrician be called when electrical problems occur.

# COMPONENT REPLACEMENT PROCEDURE

1. **Air Pump**: Follow the same procedure as outlined in the “Installation Instructions.”
2. **Float Switch**: Remove Aerobic Treatment Plant’s Riser or 24” cover. Locate float switch cable. Untie knot. Cut float switch cable. Slip float switch cable through rubber grommet into the plant. Replace with exact replacement float switch. Reinstall by reversing the procedure. Reconnect float switch wires using underground rated compound filled wire nuts. **See Float Switch Mounting Details.**
3. **Pressure Switch**: Turn all power off to the control panel. Remove back plate. Remove screws securing pressure switch as well as connectors and tubing. Reverse procedure to install new pressure switch.
4. **Buzzer**: Turn all power off to the control panel. Remove screw attaching buzzer to back plate as well as connectors. Reverse procedure to install new buzzer.
5. **Lamp holder**: Turn all power off to control power. Remove lock nut securing lamp holder to door as well as connectors. Remove lamp holder. Install new lamp holder with gaskets furnished. Continue with reverse procedure.
6. **Lamp**: Turn all power off to control panel. Remove red lamp cover from front of control panel. Remove and replace lamp which is a push in type. Replace lamp cover and cover gasket.
7. **Fuse**: Turn all power off to control panel. Pull top of fuse holder outward. Remove and replace fuse. Push fuse back into place.
8. **Buzzer Switch**: Turn all power off to control panel. Remove rubber boot on switch. Remove hex nut from switch on panel front as well as connectors on switch. Reverse procedure to install new switch.

## GENERAL COMMENTS

1. Only factory approved equipment can be used for replacement on individual treatment systems.
2. If the decision is made to pump out a system, be sure to contact a licensed waste-hauler.
3. If a chronic problem develops and all items have been checked, consult with the factory.
4. Keep good records.

### NOTE:

If the entire cover needs to be removed on any one of the various model treatment plants, the existing silicone or strip seal must be removed and replaced with a new one. This will provide a positive seal which will not allow any infiltration into or out of the treatment plant.

**APPENDIX A  
SPECIFICATIONS, DIMENSIONS AND  
TREATMENT PLANT DRAWINGS**

## SPECIFICATIONS

TREATMENT PLANT	TREATMENT CAPACITY (GPD)	TOTAL VOLUME (GAL)	AERATION VOLUME (GAL)	CLARIFIER VOLUME (GAL)	BOD LOADING (LBS/DAY)	NO. OF AIR DROPS
DF40	400	764	596	168	1.00	5
DF50	500	909	720	189	1.25	5
DF50A	500	925	732	193	1.25	5
DF60	600	1147	867	280	1.5	6
DF75	750	1438	1100	338	1.88	6
DF100	1000	1926	1470	456	2.5	8
DF100A	1000	1926	1429	497	2.5	8
DF100B	1000	2191	1759	432	2.5	8
DF150	1500	2882	2227	655	3.75	8

### MATERIALS OF CONSTRUCTION:

Suffix M	Aeration Tank	Steel
	Cover	Steel
	Clarifier	Fiberglass

Suffix F & FF*	Aeration Tank	Fiberglass
	Cover	Fiberglass
	Clarifier	Fiberglass

Suffix C	Aeration Tank	Concrete
	Cover	Fiberglass
	Clarifier	Fiberglass

Suffix CA* & CC	Aeration Tank	Concrete
	Cover	Concrete
	Clarifier	Fiberglass

**\*Standard Production Units. Other configurations are available upon special request.**

**PARTS LIST:**

**ITEM**

**MATERIALS OF CONSTRUCTION**

Aeration Tank . . . . .	1. . . . .	See Above
Clarifier . . . . .	2. . . . .	See Above
Air Distribution System . . . . .	3. . . . .	PVC
Access Cover . . . . .	4. . . . .	Polyethylene
Discharge Piping Assembly . . . . .	5. . . . .	PVC
Air Pump Assembly . . . . .	6. . . . .	See Air Pump Parts List
Sample Port . . . . .	7. . . . .	PVC
Control Panel . . . . .	8. . . . .	NEMA 3R Steel or NEMA 4X Fiberglass
High Water Float Switch . . . . .	9. . . . .	Polyethylene

**Electrical Requirements**

<u>Model</u>	<u>Compressor</u>	<u>Motor full load Amps</u>	<u>Measured Operating Watts</u>	<u>Electrical Requirements</u>
DF-40	5060A Delta Model 60	1.75 1.75	63/63 watts	115 volt - single phase
DF-50	5060A/5080S/5078S/0323/ QR-0030/EL-80-17 Delta Model 60 Delta Model 80	1.75/2.1/ 2.1/4.0/ 5.6/1.8 1.75/2.1	63/85/85/391/ 300/131/63/85 Watts	115 volt - single phase
DF-60	5080A/0523/5100S/QR-50/ EL-80-17 Delta Model 80 Delta Model 100	2.1/4.6/ 2.71/5.3/ 1.8 2.1/2.71	85/449/110/ 518/131/85/ 110 Watts	115 volt - single phase
DF-75	5100S/5120S/QR-50/0523 Delta Model 100 Delta Model 120	2.71/2.8/ 5.3/4.6/2.7 1/2.8	110/157/ 518/449/110/1 57 Watts	115 volt - single phase
DF-100	(2)5080S/(1)QR-0080/ (2) EL-80-17 (2) Delta Model (80)	(2)2.1 (1)10.4 (2)1.8 (2) 2.1	(2) 85 Watts (1)640 Watts (2)131 Watts (2) 85 watts	115 volt - single phase
DF-150	(3)5100S/(1)QR-0100/ (2)5120S (3) Delta Model 100 (2) Delta Model 120	(3)2.71 (1)10.4 (2)2.8 (3) 2.71 (2) 2.8	(3)110 Watts (1)850 Watts (2)157 watts (3) 110 watts (2) 157 watts	115 volt - single phase

## DIMENSIONS

TREATMENT PLANT	A	B	C	D	E	F	G	H
DF40	4'-11 3/16"	4'-8 3/16"	5'-6"	4'-5 9/16"	5'-0"	10"	6'-0"	10"
DF50	4'-11 3/16"	4'-8 3/16"	6'-0"	4'-5 9/16"	5'-0"	10"	6'-6"	10"
DF50A	5'-10 3/16"	5'-7 3/16"	5' -6"	5'-4 9/16"	5'- 11"	10"	6'-0"	10"
DF60	5'-7 3/4"	5'-4"	6'-3"	5'-1 1/2"	5'-9"	11 1/2"	6'-9"	10"
DF75	6'-0 1/2"	5'-8 1/2"	6'-9"	5'-6"	6'-2"	11 1/2"	7'-3"	10"
DF100	6'-5 5/8"	6'-2"	7'-6"	5'-11 1/2"	6'-8"	1'-0"	8'-0"	10"
DF100A	5'-9 5/8"	5'-6"	8'-0"	5'-3"	6'-0"	1'-0"	8'-6"	10"
DF100B	6'-5 5/8"	6'-2"	8'-0"	5'-11 1/2"	6'-8"	1'-1"	8'-6"	10"
DF150	8'-3 5/8"	8'-0"	8'-0"	7'-9 1/2"	8'-6"	1'-3 3/4"	8'-6"	10"

**REFER TO TREATMENT PLANT DRAWINGS ON THE ABOVE DIMENSIONS.**

**NOTE: For special cargo or container shipments 12 inches must be added to the diameters of all fiberglass units (due to the fiberglass flange and lifting lugs).**

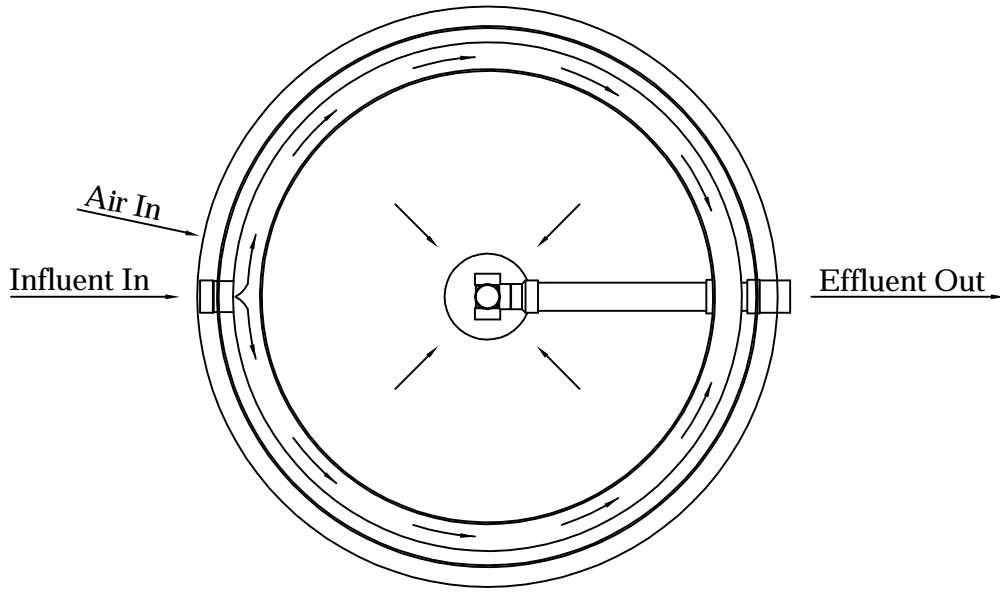

**Plan View**  
(with cover removed)

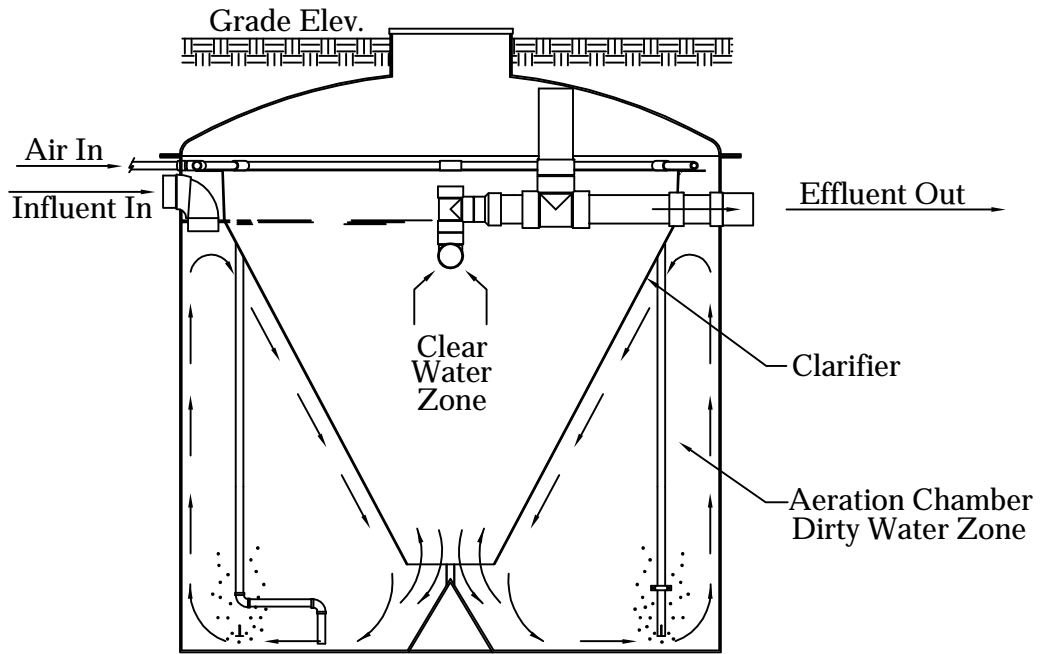

**Section**



Delta Environmental Products  
P.O. Box 969 Denham Springs, LA 70727

**FLOW DIAGRAM  
TREATMENT PLANTS**

DWN BY: B.LANDRY	DATE: 06/19/03	SCALE: N.T.S.	DWG. NO.: CRT600
---------------------	-------------------	------------------	---------------------

Note: See dimension sheet for number of air drops

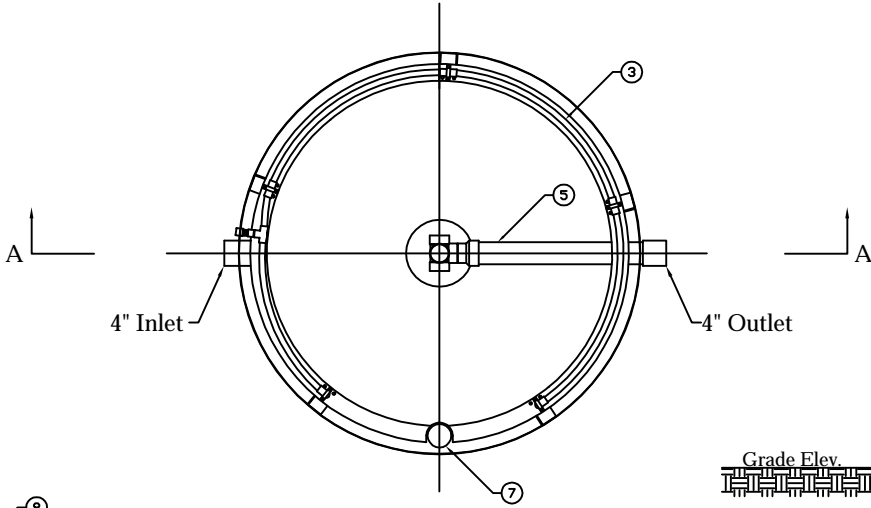

Plan View  
(with cover removed)

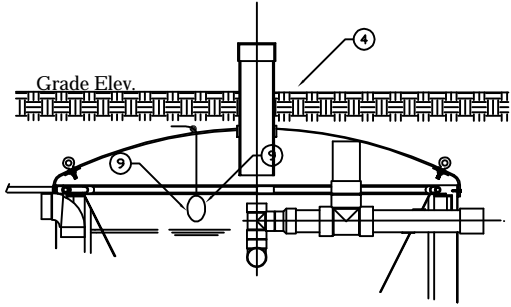

Alternate Access Port

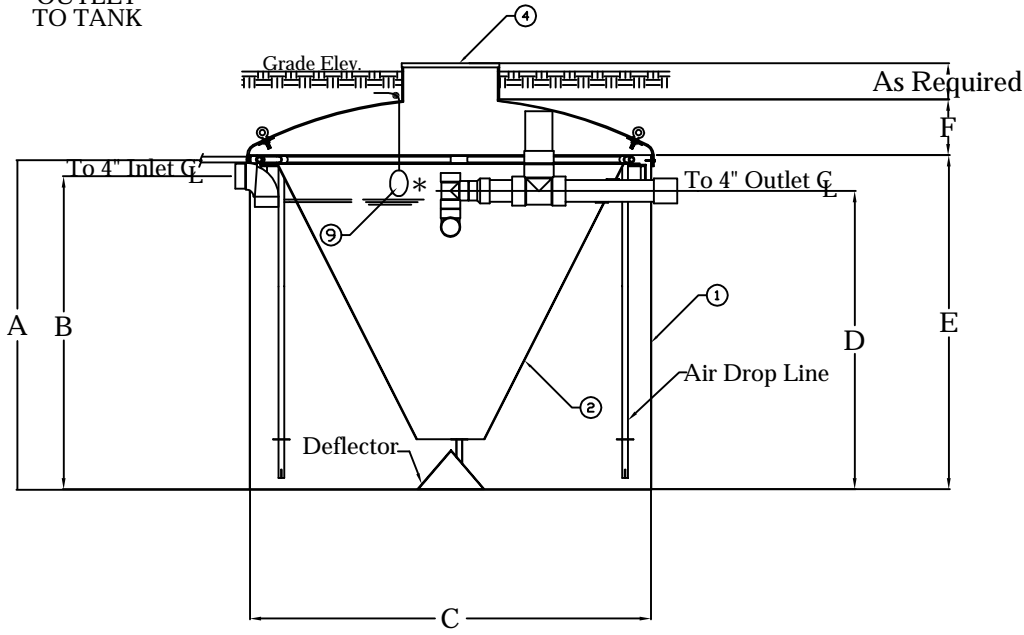
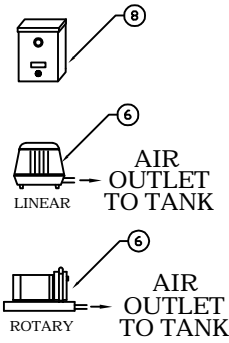

Section A-A

\* HIGH LEVEL FLOAT NOT REQUIRED WHEN USING CP22 SERIES CONTROL PANELS



Delta Environmental Products  
P.O. Box 969 Denham Springs, LA 70727

WASTEWATER TREATMENT UNITS  
MODEL DFXX-M

DWN BY: B.LANDRY	DATE: 06/19/03	SCALE: N.T.S.	DWG. NO.: CRT601
---------------------	-------------------	------------------	---------------------





Note: See dimension sheet for number of air drops

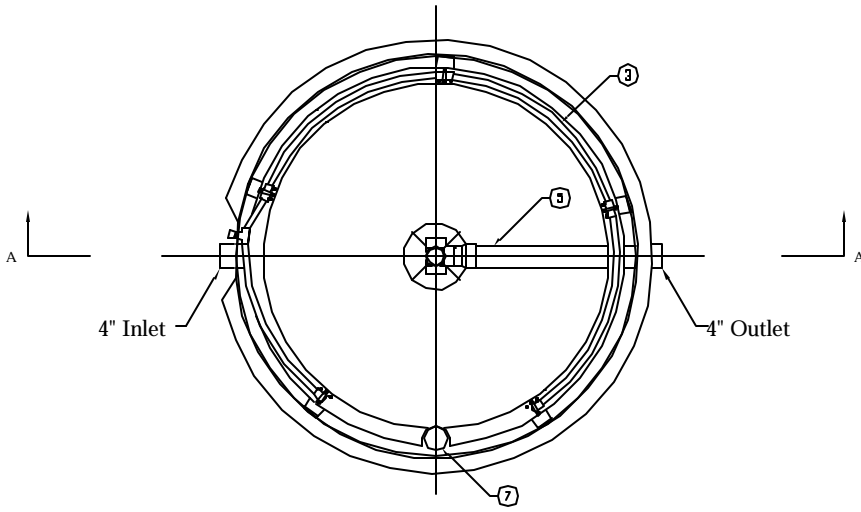

Plan View  
(with cover removed)

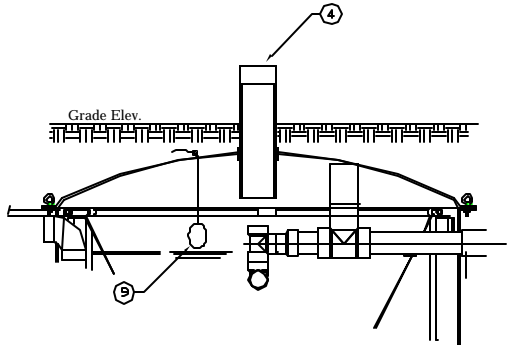

Alternate Access Port

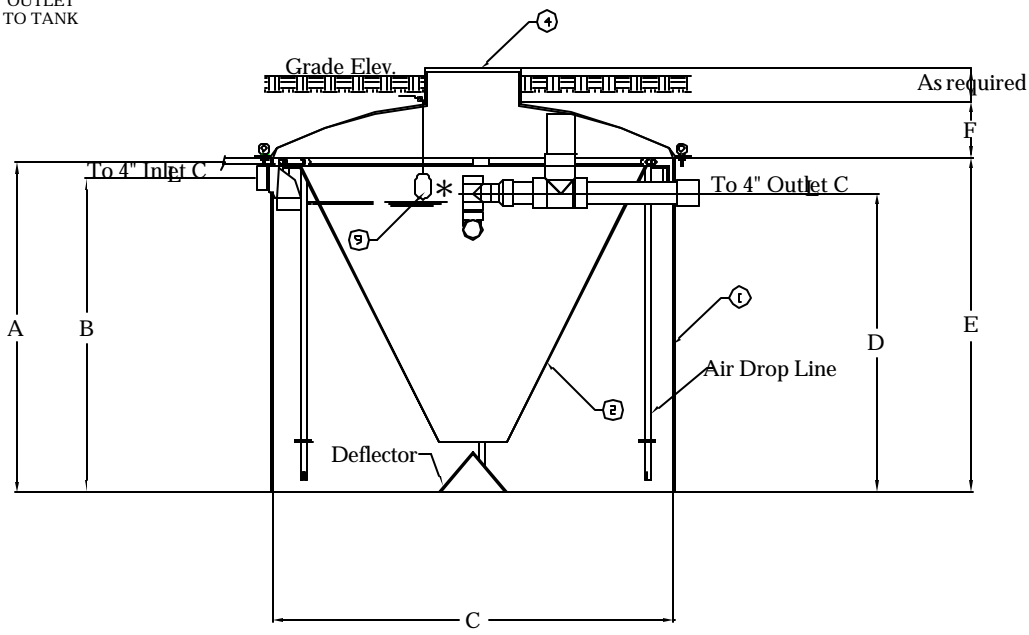
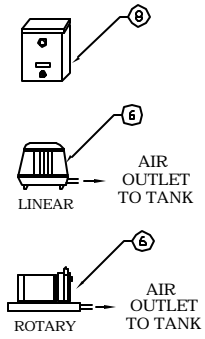

Section A-A

\* HIGH LEVEL FLOAT NOT REQUIRED WHEN USING CP22 SERIES CONTROL PANELS



Delta Environmental Products, Inc.  
P.O. Box 969 Denham Springs, LA 70727

WASTEWATER TREATMENT UNITS  
MODEL DFXX-FF

DWN BY: B.LANDRY	DATE: 06/19/03	SCALE: N.T.S.	DWG. NO.: CRT603
---------------------	-------------------	------------------	---------------------

Note: See dimension sheet for number of air drops

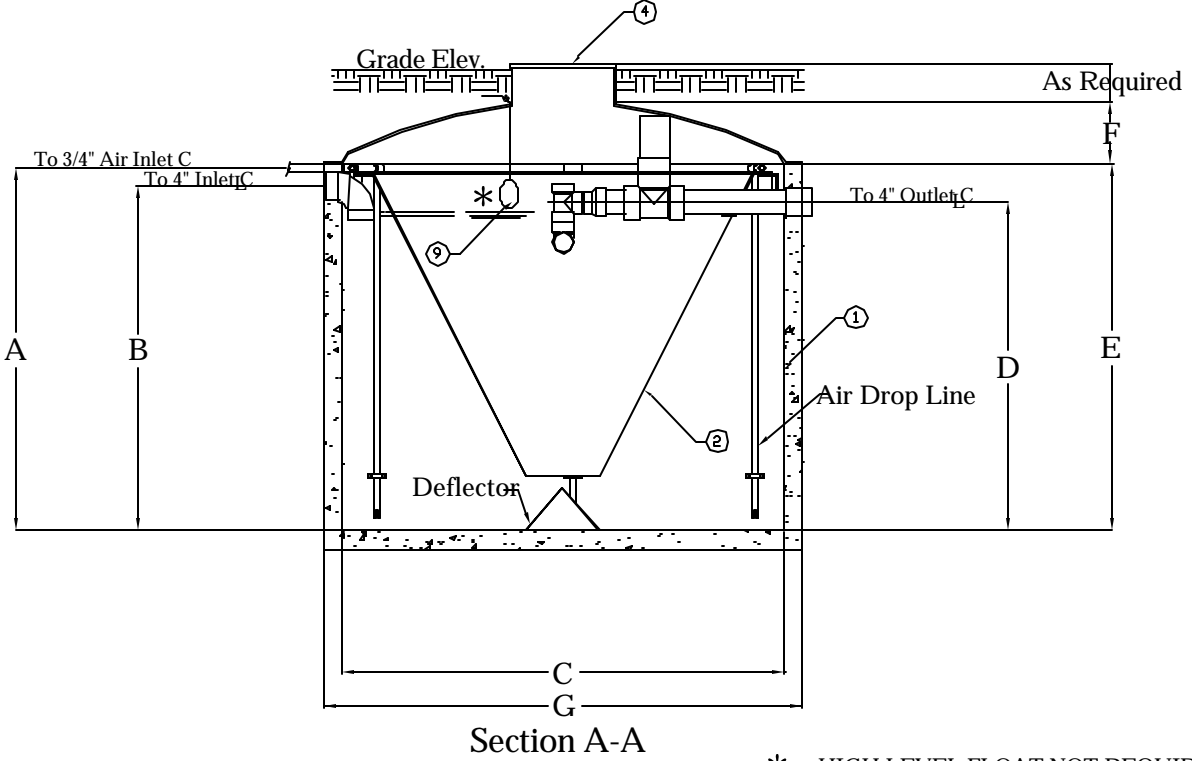
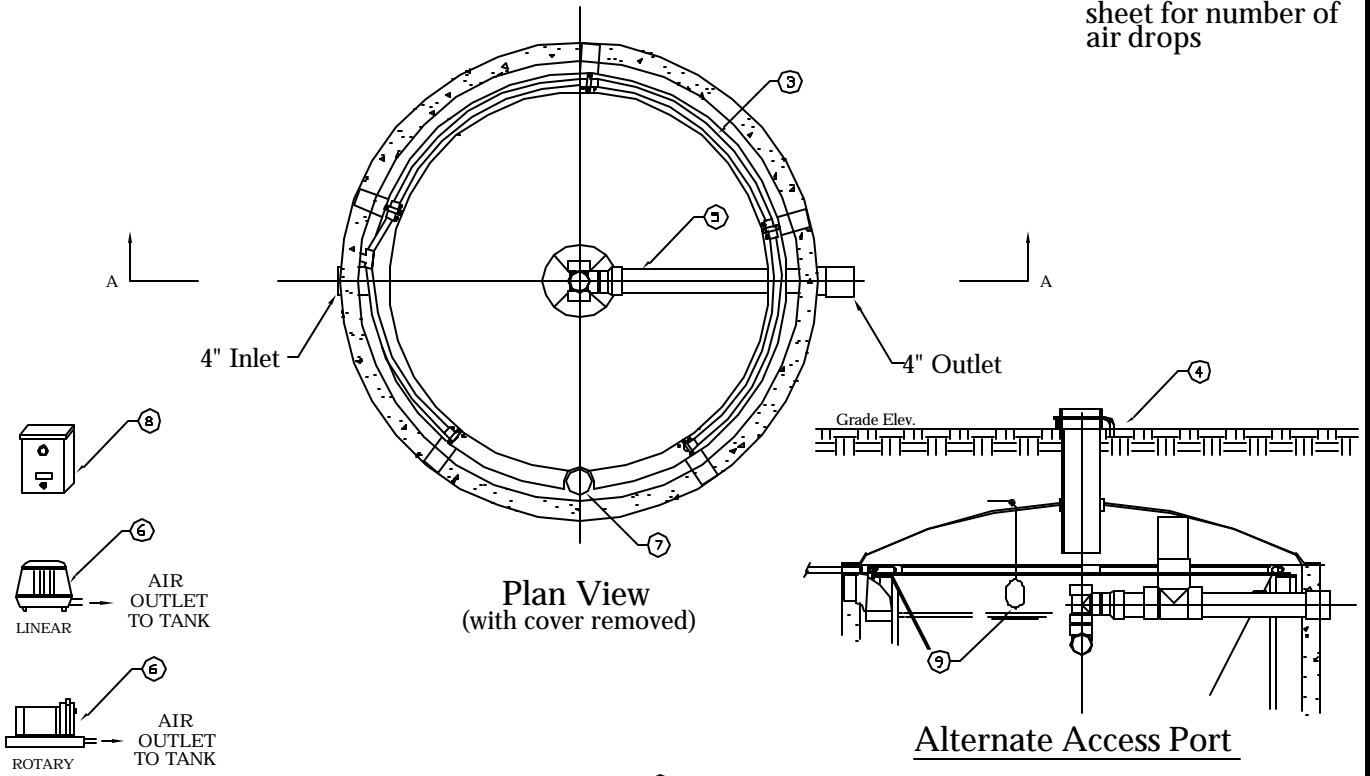

\* HIGH LEVEL FLOAT NOT REQUIRED WHEN USING CP22 SERIES CONTROL PANELS



Delta Environmental Products, Inc.  
P.O. Box 969 Denham Springs, LA 70727

# WASTEWATER TREATMENT UNITS MODEL DFXX-C

DWN BY: B.LANDRY	DATE: 06/19/03	SCALE: N.T.S.	DWG. NO.: CRT604
---------------------	-------------------	------------------	---------------------

Note: See dimension sheet for number of air drops

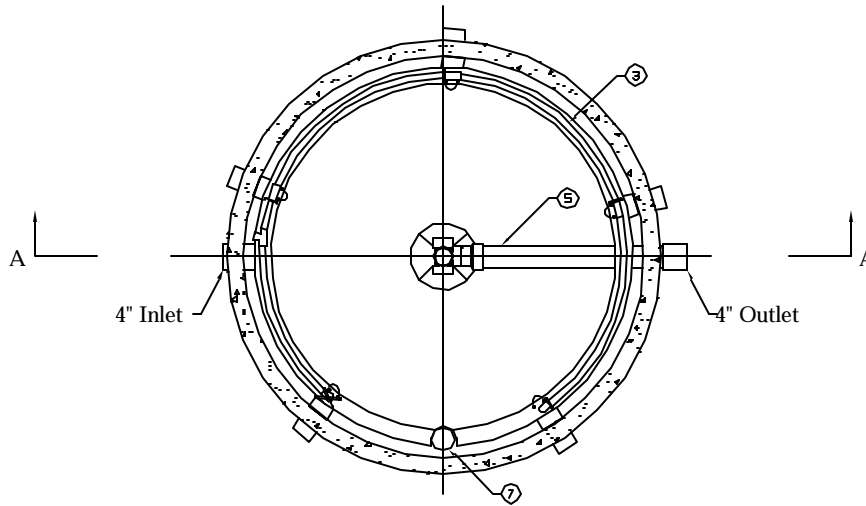

Plan View  
(with cover removed)

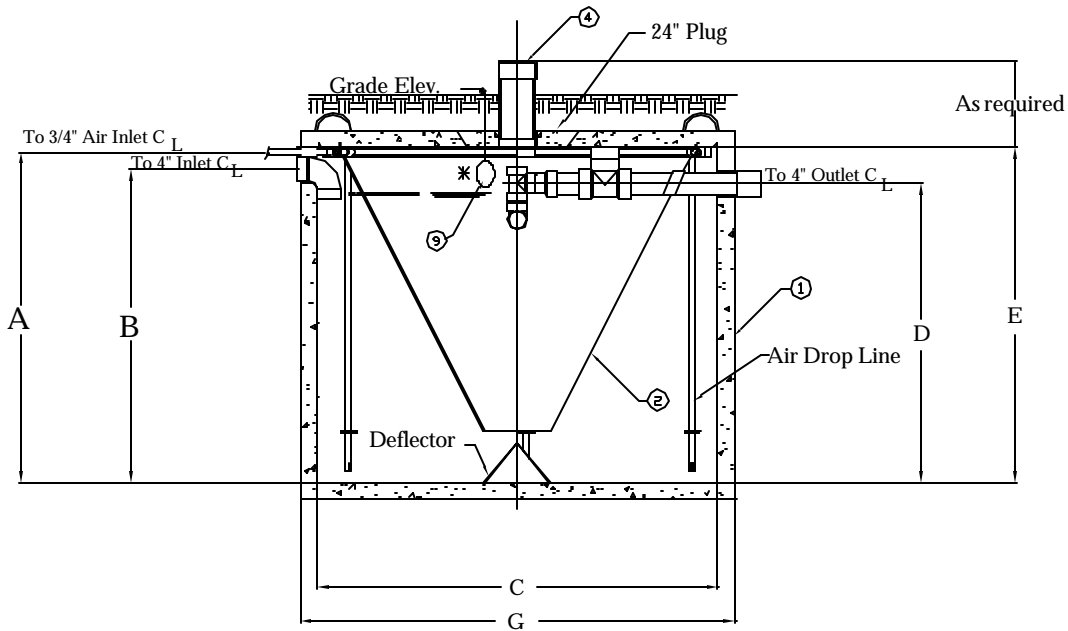
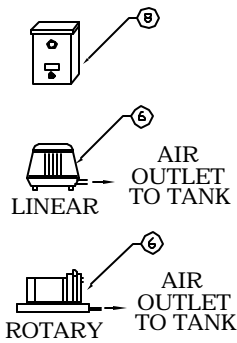

Section A-A

\* HIGH LEVEL FLOAT NOT REQUIRED  
WHEN USING CP22 SERIES CONTROL PANELS



Delta Environmental Products, Inc.  
P.O. Box 969 Denham Springs, LA 70727

## WASTEWATER TREATMENT UNITS MODEL DFXX-CA

DWN BY:  
B.LANDRY

DATE:  
06/19/03

SCALE:  
N.T.S.

DWG. NO.:  
CRT605

**APPENDIX B**  
**ELECTRICAL DRAWINGS**

# DIRECT AIRLINE TAP INSTALLATION METHOD

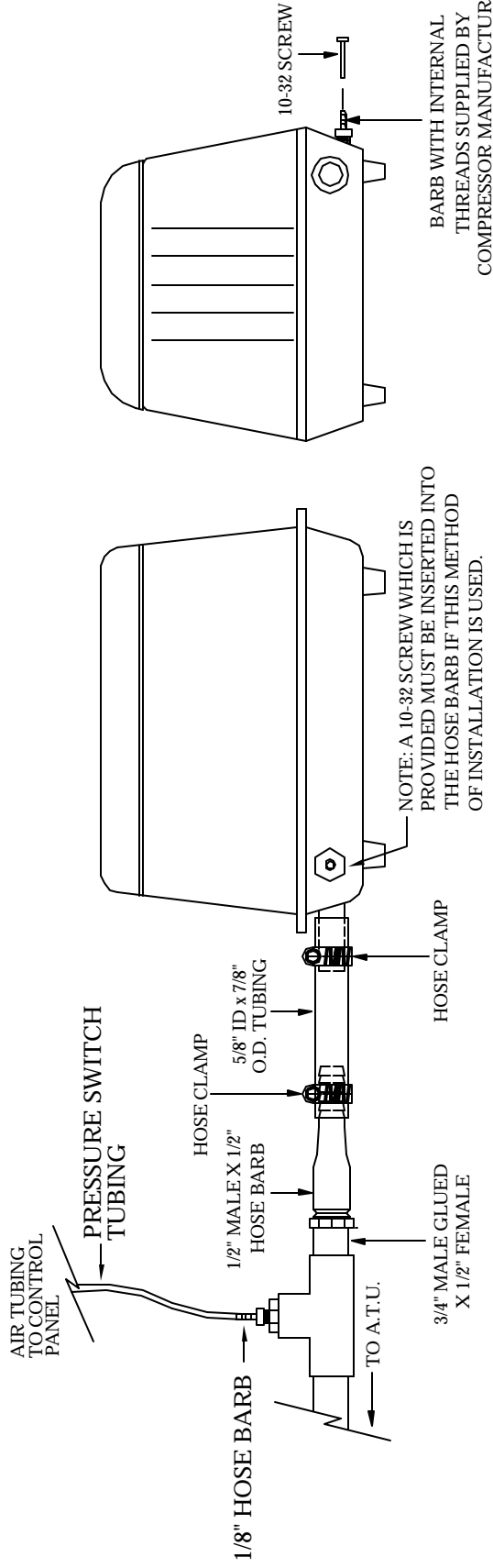

# COMPRESSOR AIRLINE TAP INSTALLATION METHOD

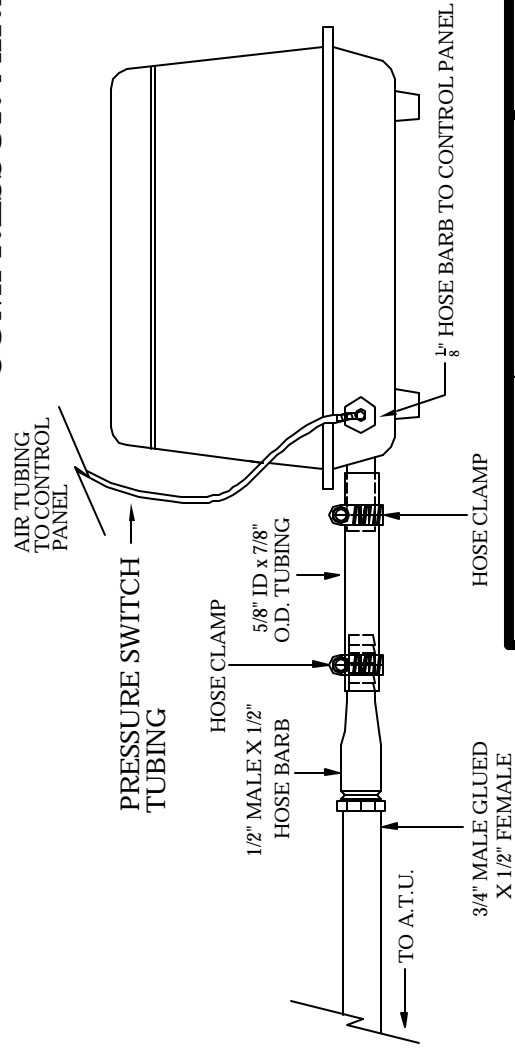

DELTA ENVIRONMENTAL PRODUCTS, INC.  
P. O. BOX 969 DENHAM SPRINGS, LA 70727

# TUBING CONNECTION ASSEMBLY DRAWING

DWN BY:  
BLANDRY

DATE:  
04/29/04

SCALE:  
N.T.S.

DWG. NO.:  
DEP005

CP23 CONTROL PANEL

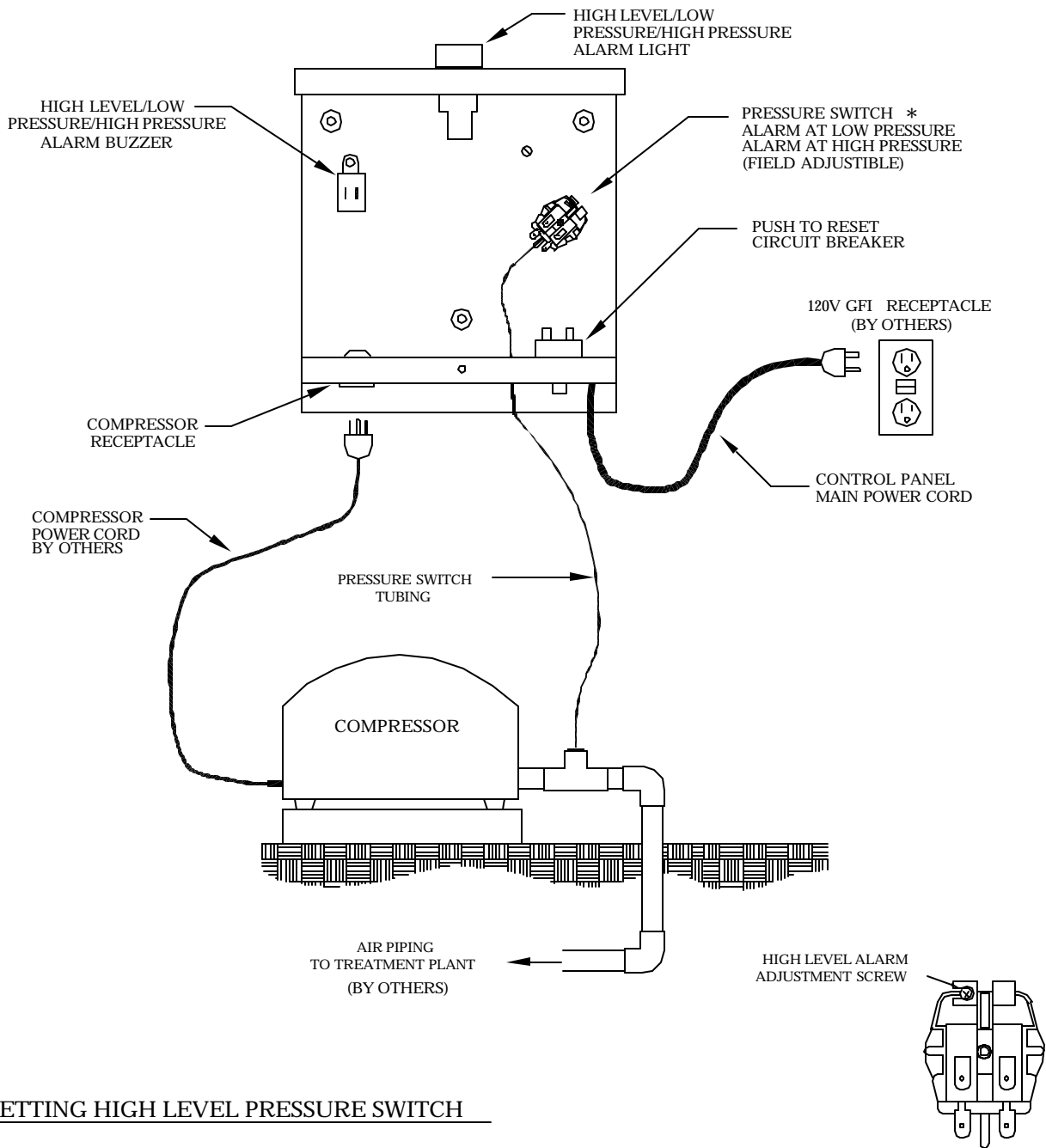

SETTING HIGH LEVEL PRESSURE SWITCH

BRING PLANT TO OPERATING WATER LEVEL WITH COMPRESSOR TURNED ON.  
 USING PROPERLY SIZED SCREW DRIVER, TURN HIGH LEVEL ALARM ADJUSTMENT  
 SCREW CLOCKWISE UNTIL ALARM OCCURS. THEN TURN THE SCREW COUNTER-CLOCKWISE  
 UNTIL ALARM STOPS.



Delta Environmental Products, Inc.  
 P.O. Box 969 Denham Springs, LA 70727

CONTROL PANEL CONNECTIONS  
 MODEL CP 23

DWN BY: B.LANDRY	DATE: 06/19/03	SCALE: N.T.S.	DWG. NO.: CRT305
---------------------	-------------------	------------------	---------------------

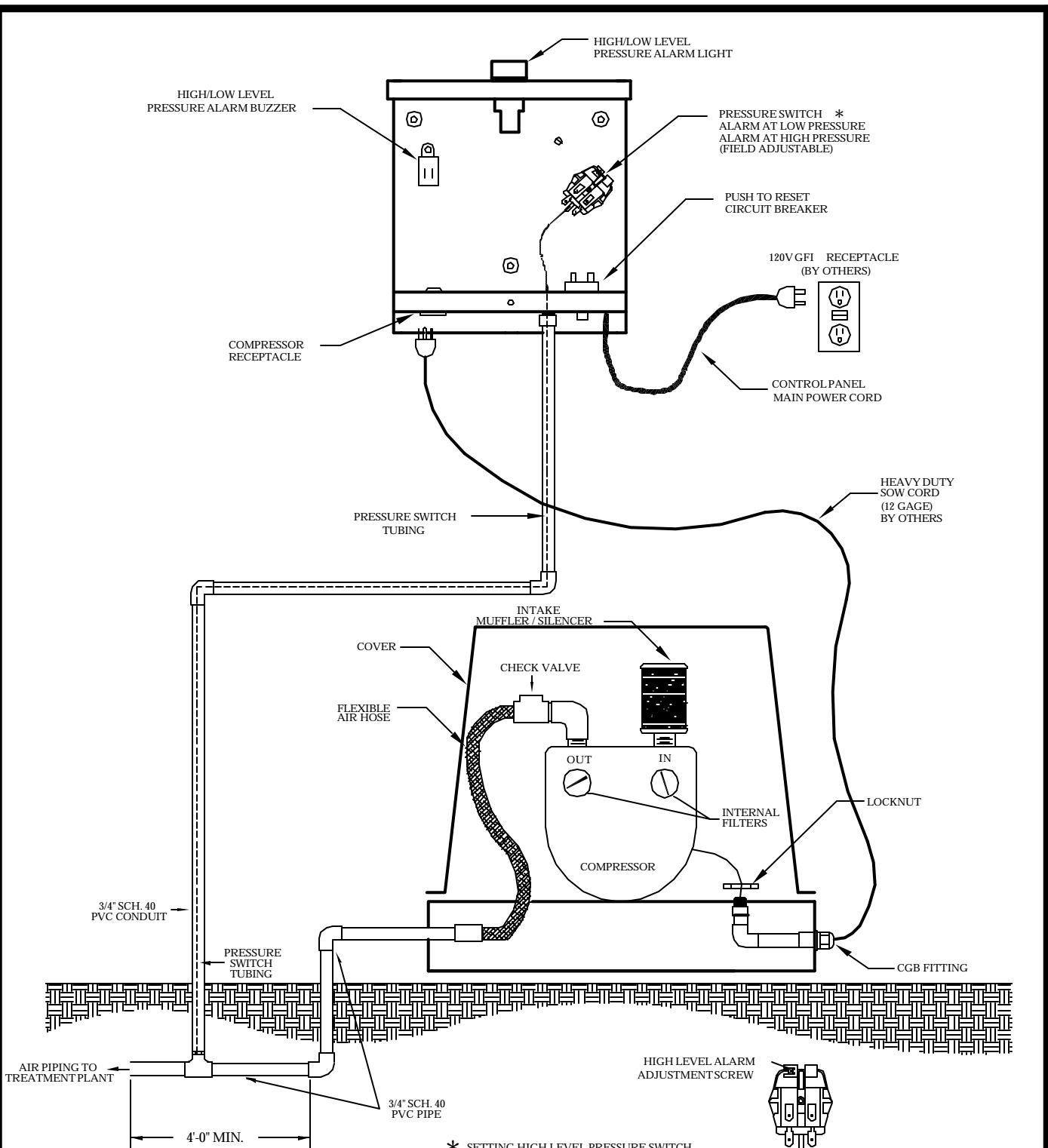

**\* SETTING HIGH LEVEL PRESSURE SWITCH**

BRING PLANT TO OPERATING WATER LEVEL WITH COMPRESSOR TURNED ON. USING PROPERLY SIZED SCREW DRIVER, TURN HIGH LEVEL ALARM ADJUSTMENT SCREW CLOCKWISE UNTIL ALARM OCCURS. THEN TURN THE SCREW COUNTER-CLOCKWISE UNTIL ALARM STOPS.

**CP 23 CONTROL PANEL CONNECTIONS  
USING QR SERIES COMPRESSORS**



DELTA ENVIRONMENTAL PRODUCTS, INC.  
P. O. BOX 969 DENHAM SPRINGS, LA 70727

DWN BY:  
**B.LANDRY**

DATE:  
**07/17/03**

SCALE:  
**N.T.S.**

DWG. NO.:  
**DEP044**

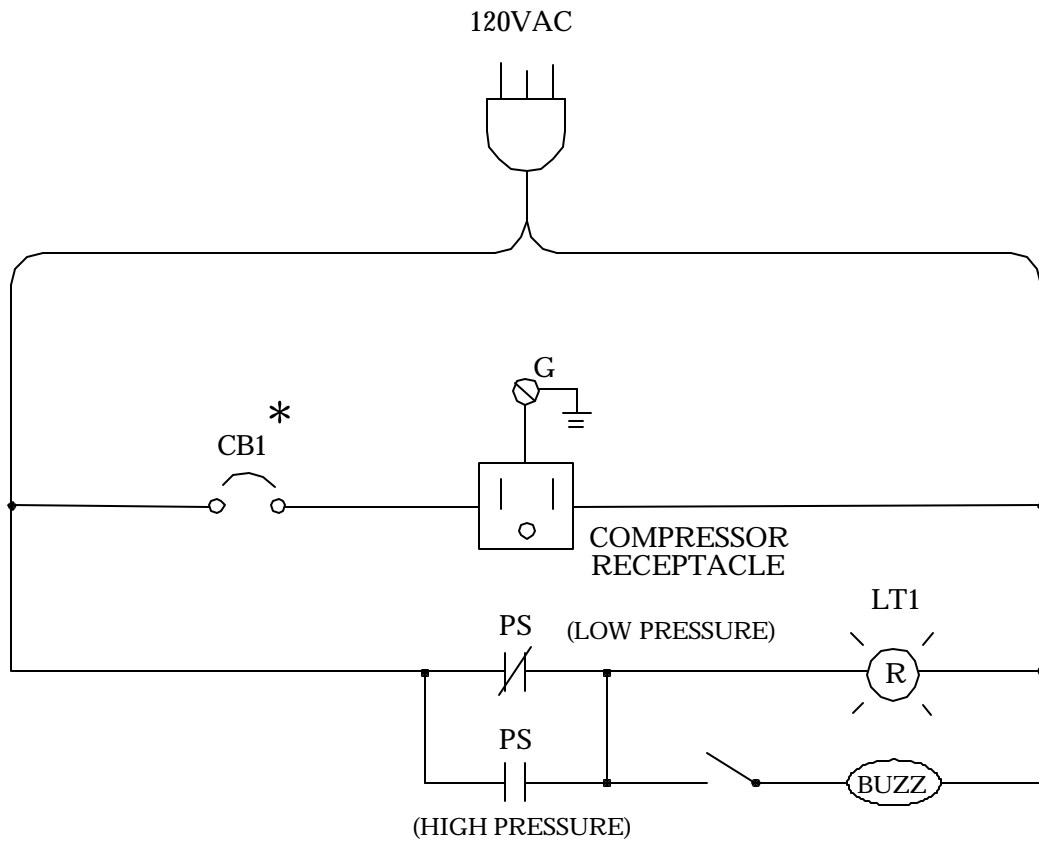

SCHEMATIC DIAGRAM  
CP23

\* SIZE VARIES WITH  
COMPRESSOR SIZE PER  
NATIONAL ELECTRICAL CODE



Delta Environmental Products, Inc.  
P.O. Box 969 Denham Springs, LA 70727

**SCHEMATIC DIAGRAM**  
**CP 23SW**

DWN BY:  
B.LANDRY

DATE:  
06/19/03

SCALE:  
N.T.S.

DWG. NO.:  
CP23

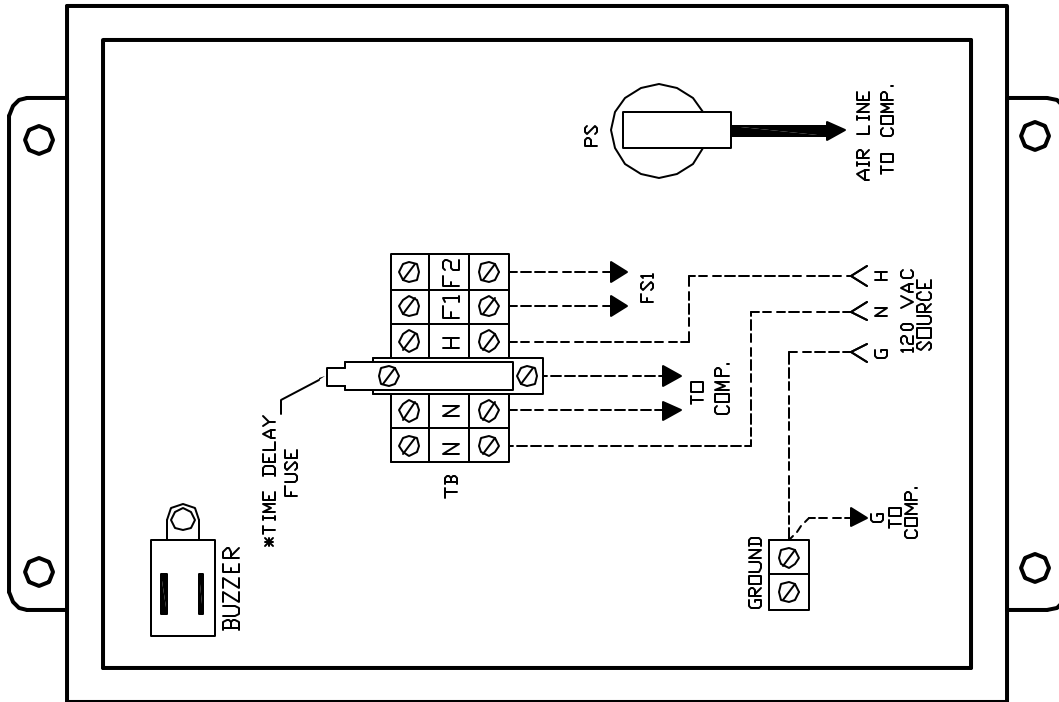

FS1-FLOAT SWITCH IN TREATMENT PLANT  
 \* FUSE SIZE VARIES WITH COMPRESSOR SIZE  
 PER NATIONAL ELECTRIC CODE

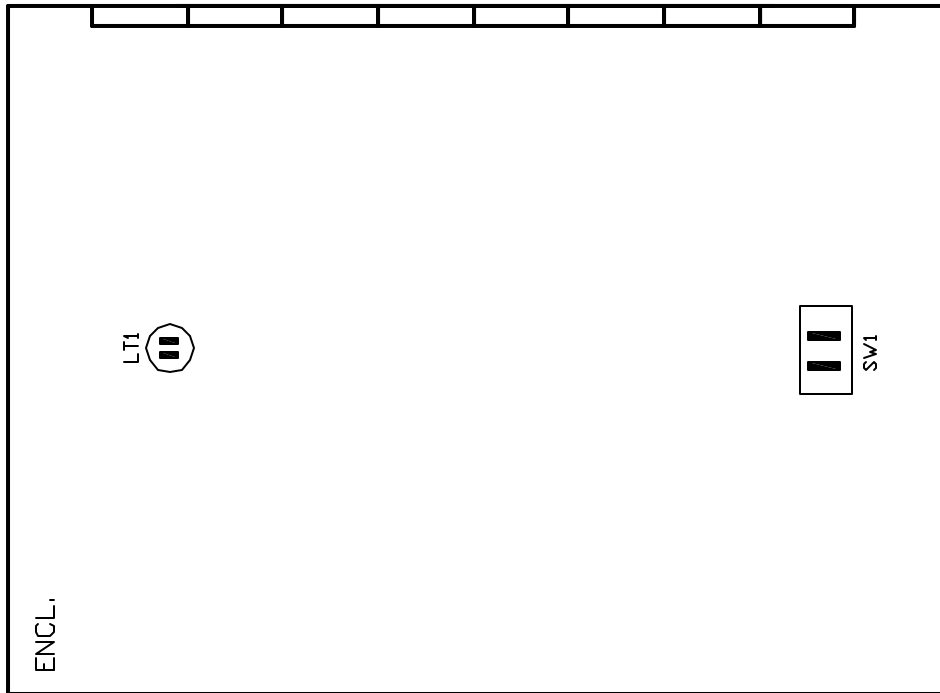

FRONT VIEW  
DOOR OPEN  
 CP20



DELTA ENVIRONMENTAL PRODUCTS, INC.  
 P. O. BOX 969 DENHAM SPRINGS, LA 70727

# CP20 PANEL

DWN BY:  
 B.LANDRY

DATE:  
 04/09/03

SCALE:  
 N.T.S.

DWG. NO.:  
 CP20

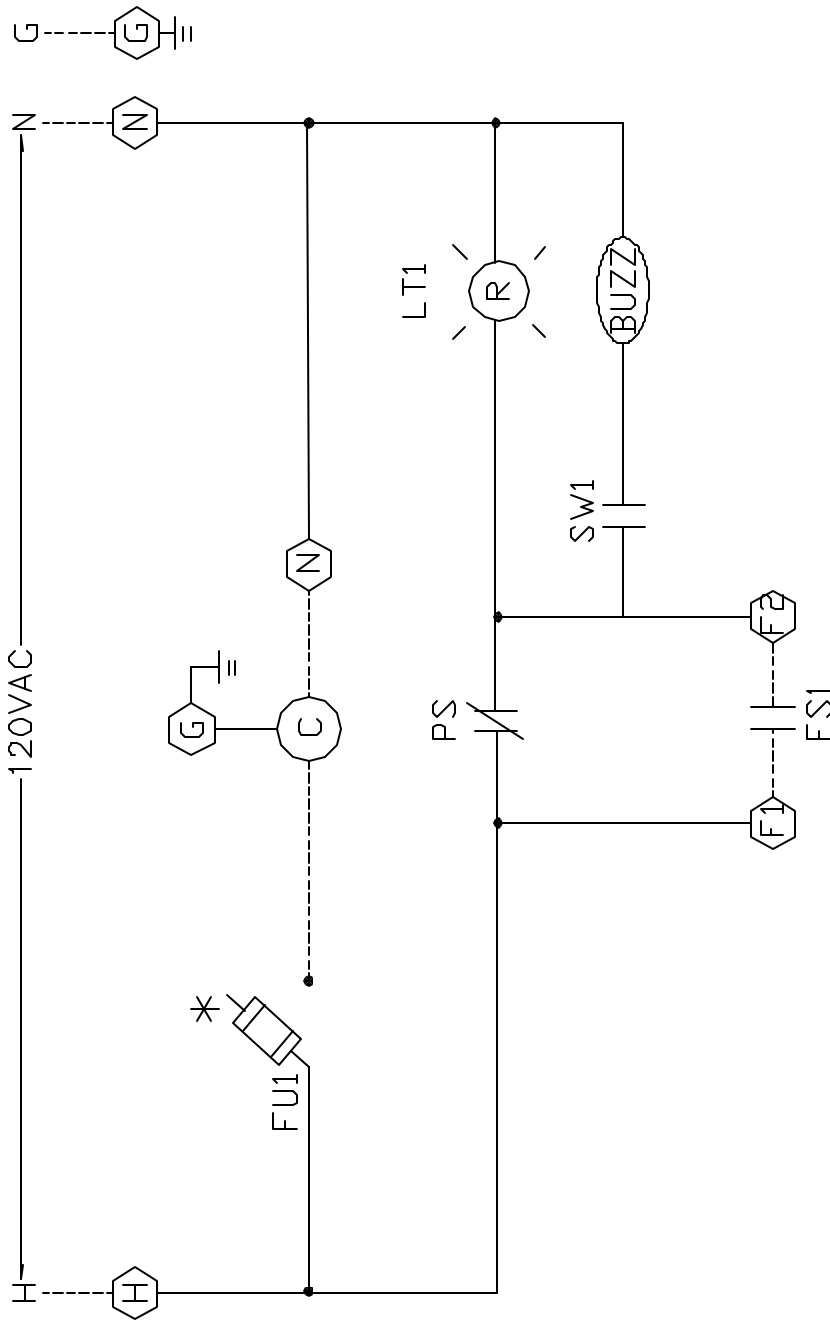

SCHEMATIC DIAGRAM  
CP20 SERIES

\* FUSE SIZE VARIES WITH COMPRESSOR SIZE  
PER NATIONAL ELECTRICAL CODE



DELTA ENVIRONMENTAL PRODUCTS, INC.  
P. O. BOX 969 DENHAM SPRINGS, LA 70727

## CP20 WIRING DIAGRAM

DWN BY:  
B.LANDRY

DATE:  
04/09/03

SCALE:  
N.T.S.

DWG. NO.:  
CP20

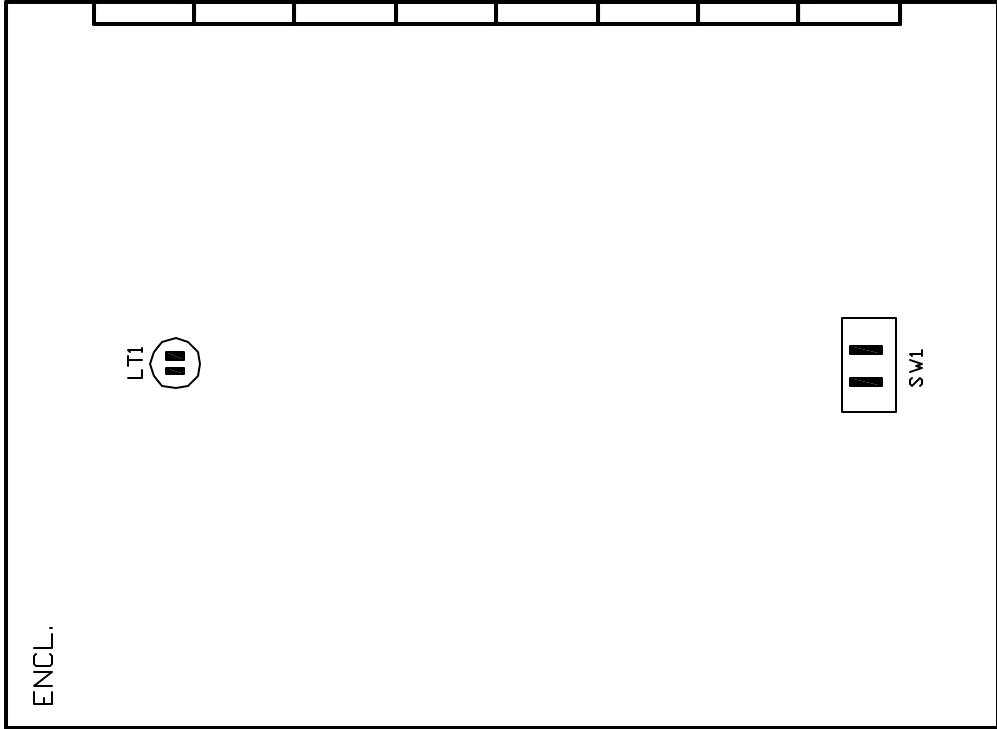
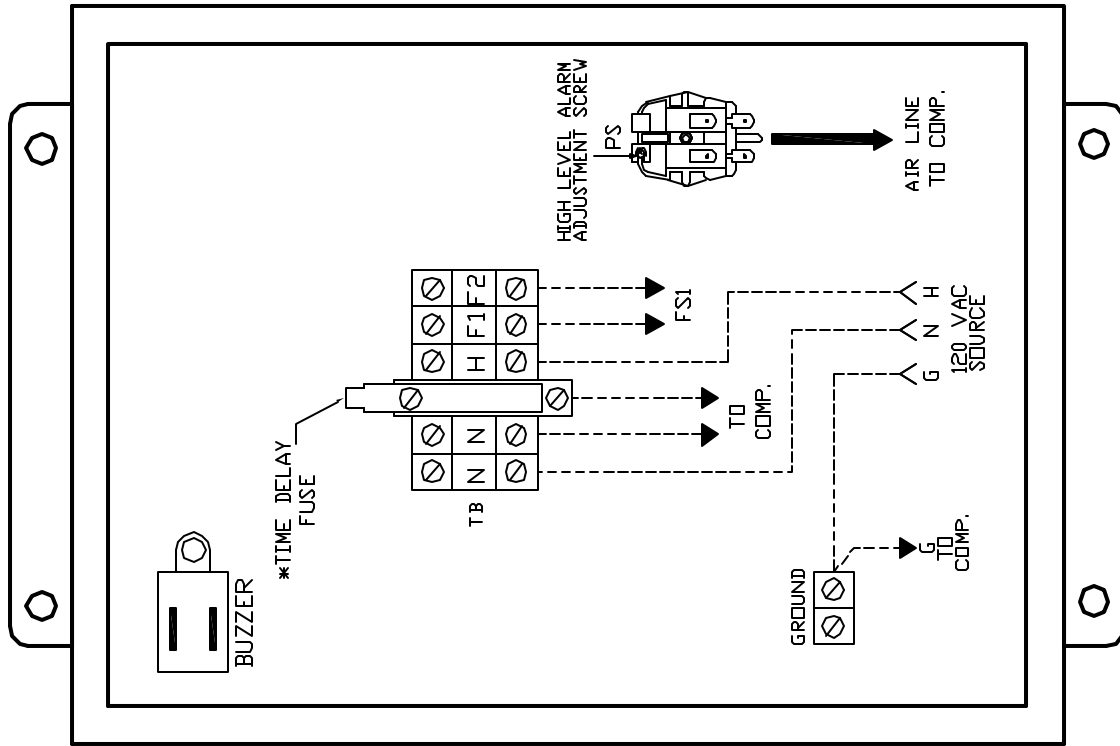

FRONT VIEW  
 DOOR OPEN  
 CP22

FS1-FLOAT SWITCH IN TREATMENT PLANT  
 \* FUSE SIZE VARIES WITH COMPRESSOR SIZE  
 PER NATIONAL ELECTRIC CODE



DELTA ENVIRONMENTAL PRODUCTS, INC.  
 P. O. BOX 969 DENHAM SPRINGS, LA 70727

# CP 22 PANEL

DWN BY:  
 B.LANDRY

DATE:  
 04/09/03

SCALE:  
 N.T.S.

DWG. NO.:  
 CP22P

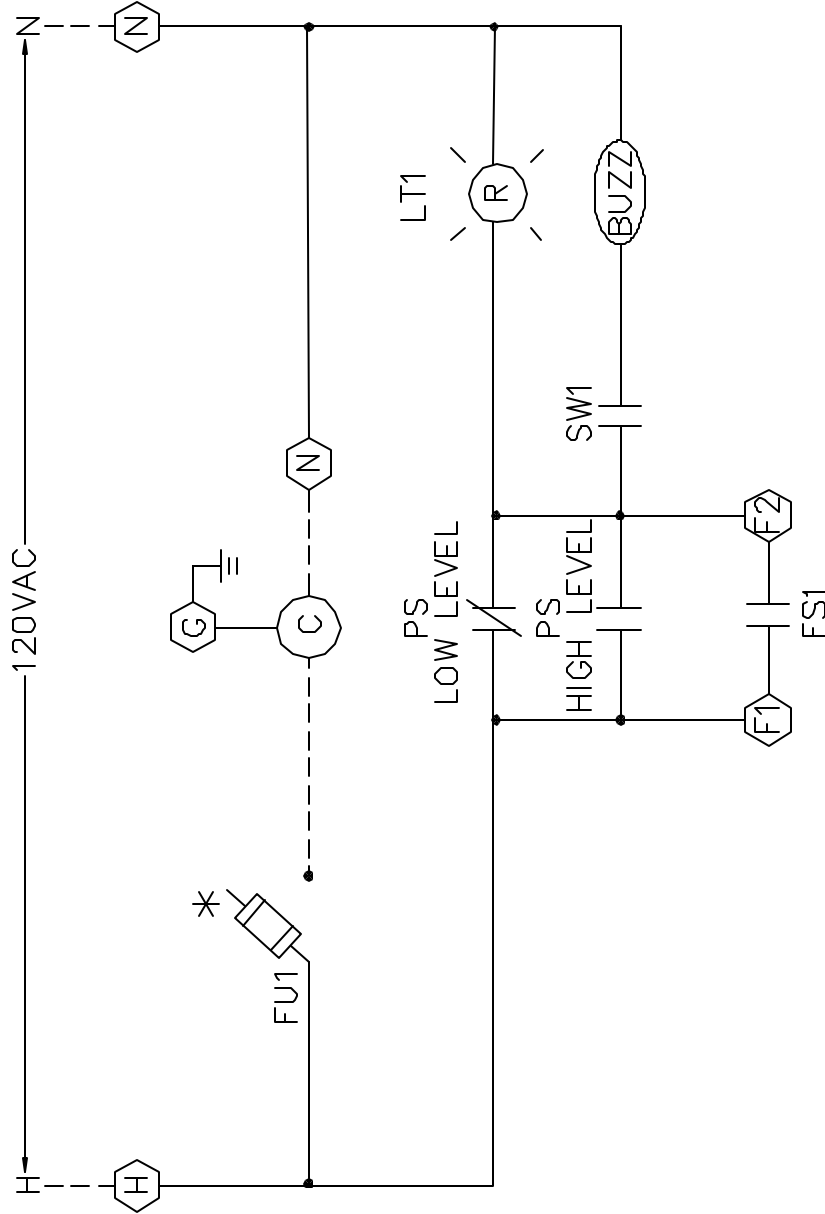

SCHEMATIC DIAGRAM

CP22 SERIES

FS1- H.L. FLOAT SWITCH (OPTIONAL)

\* FUSE SIZE VARIES WITH COMPRESSOR SIZE PER NATIONAL ELECTRICAL CODE

-A SEPERATE DISCONNECT IS REQUIRED.

DWG . CP22



DELTA ENVIRONMENTAL PRODUCTS, INC.  
P. O. BOX 969 DENHAM SPRINGS, LA 70727

CP 22 WIRING DIAGRAM

DWN BY:  
B.LANDRY

DATE:  
04/09/03

SCALE:  
N.T.S.

DWG. NO.:  
CP22

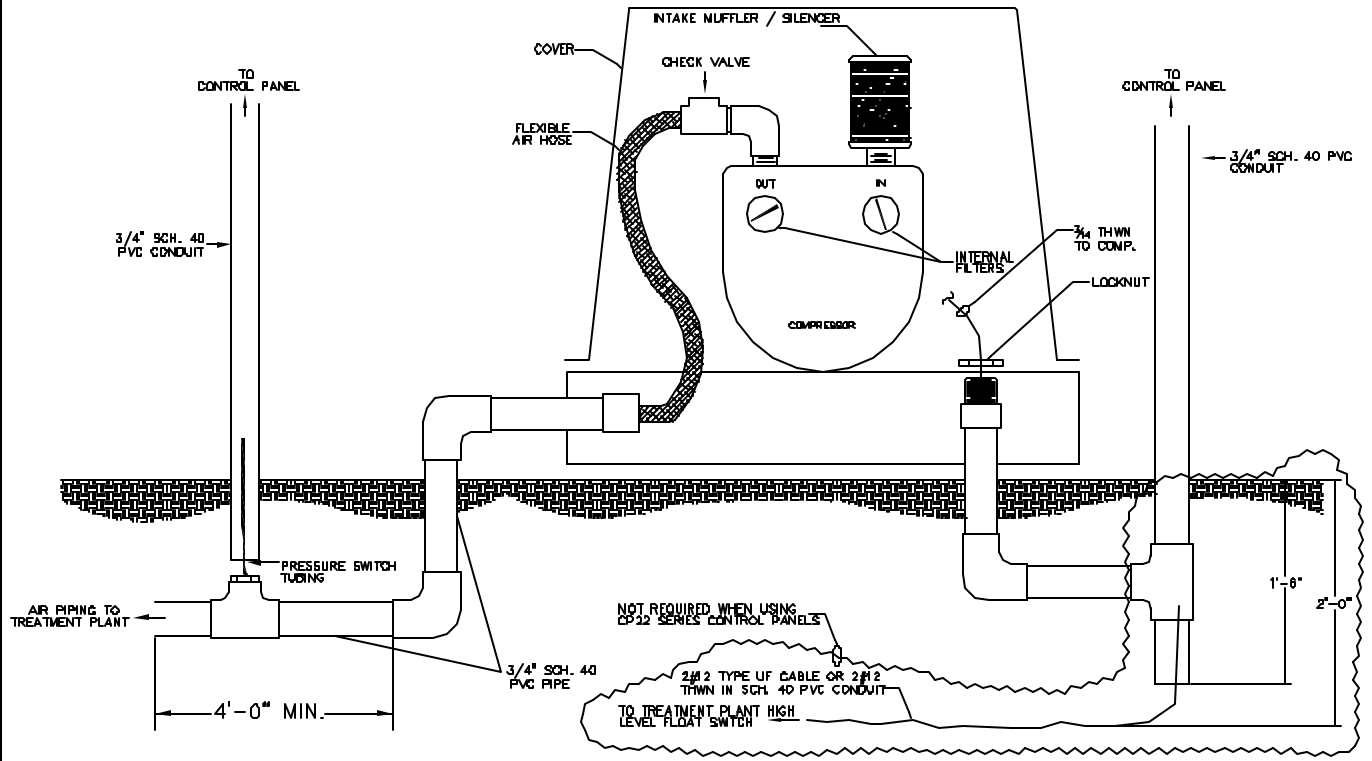
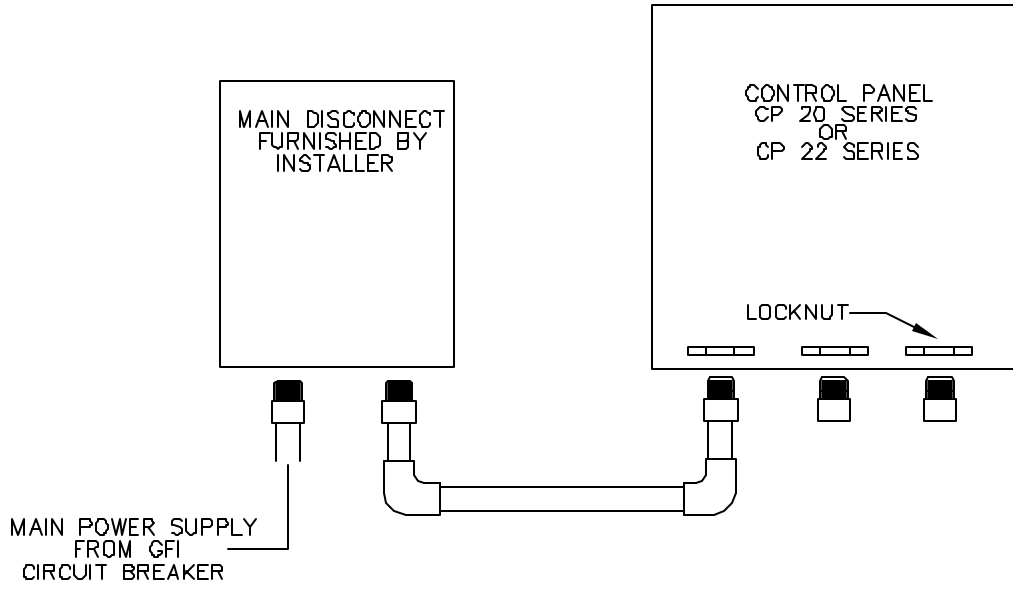

DELTA ENVIRONMENTAL PRODUCTS, INC.  
 P. O. BOX 969 DENHAM SPRINGS, LA 70727

### CONTROL PANEL CONNECTIONS USING ROTARY SERIES COMPRESSORS

DWN BY:  
 B.LANDRY

DATE:  
 04/09/03

SCALE:  
 N.T.S.

DWG. NO.:  
 CRT610

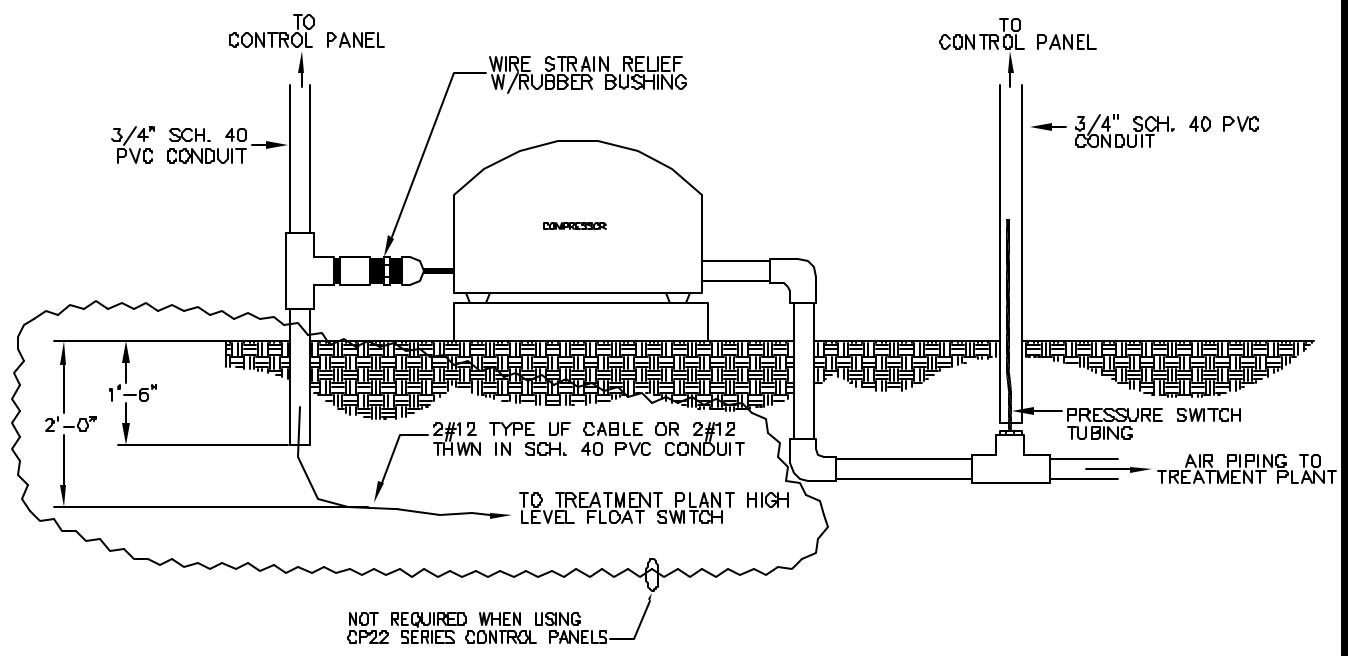
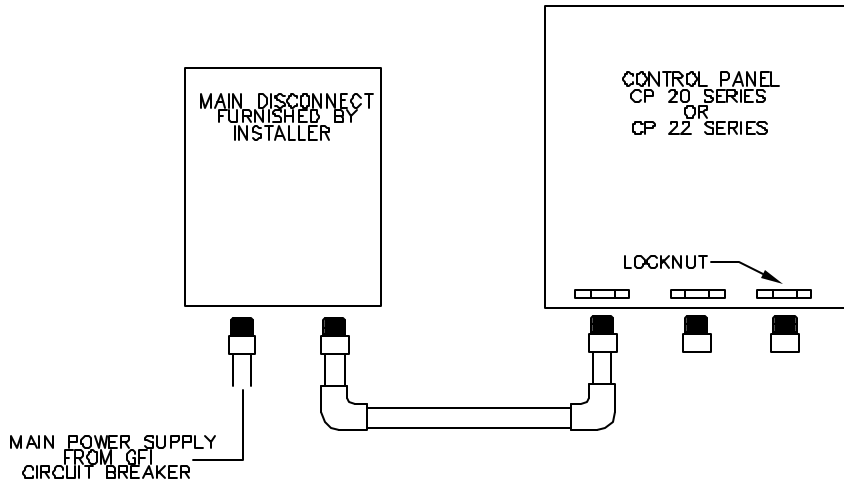

DELTA ENVIRONMENTAL PRODUCTS, INC.  
P. O. BOX 969 DENHAM SPRINGS, LA 70727

### CONTROL PANEL CONNECTIONS USING LINEAR COMPRESSOR

DWN BY:  
B.LANDRY

DATE:  
04/09/03

SCALE:  
N.T.S.

DWG. NO.:  
CRT609

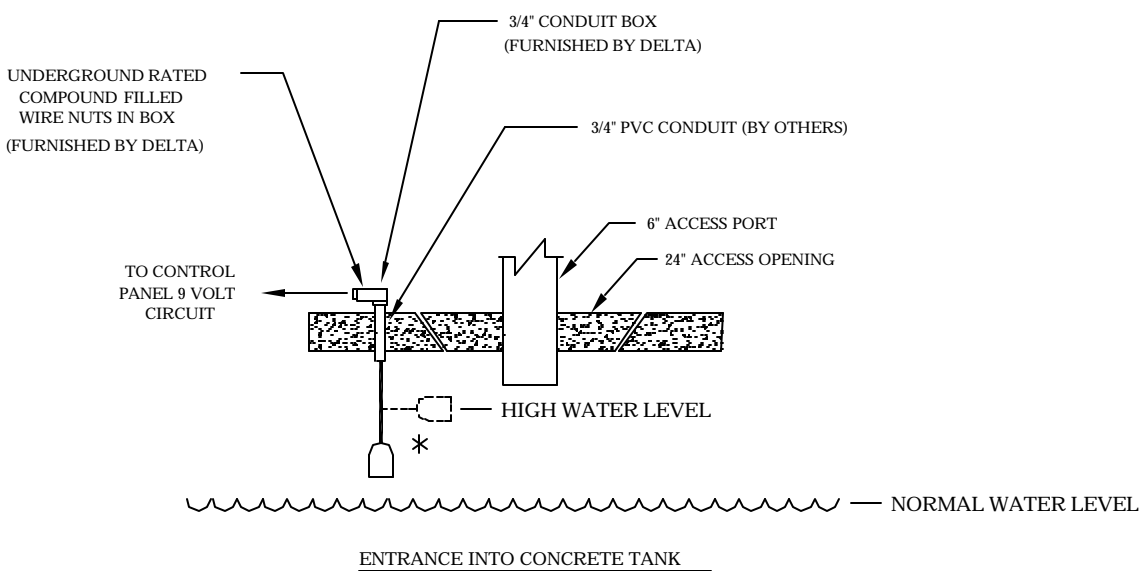
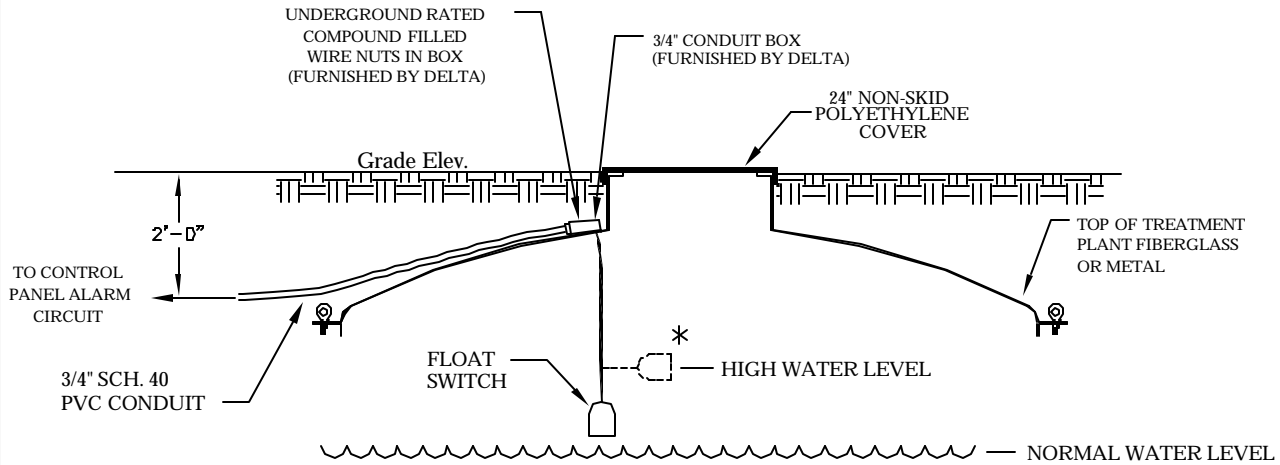

NOTES:

1. GROMMET TO BE SELECTED FOR TIGHT FIT AROUND CABLE AND IN LID.
2. WIRE TO CONTROL PANEL TO BE 18 GAUGE AND RATED FOR DIRECT BURIAL SERVICE. WOODS WIRE-886 OR EQUAL.
3. WIRE NUTS TO BE RATED FOR UNDERGROUND SERVICE IDEAL-DB PLUS MODEL 60 OR EQUAL.
4. FLOAT SWITCH TO BE NORMALLY OPEN MDI-AS10Y0500 OR EQUAL.
5. SMALL ACCESS PORT SHOWN ON DRAWING LARGE ACCESS PORTS MAY BE SUPPLIED.
6. MINIMUM AMOUNT OF CONDUIT SHOWN ABOVE IS REQUIRED EVEN WITH TYPE UF CABLE.

\* HIGH LEVEL FLOAT NOT REQUIRED WHEN USING CP22 SERIES CONTROL PANELS



DELTA ENVIRONMENTAL PRODUCTS, INC.  
P. O. BOX 969 DENHAM SPRINGS, LA 70727

## FLOAT SWITCH MOUNTING

DWN BY:  
B.LANDRY

DATE:  
04/09/03

SCALE:  
N.T.S.

DWG. NO.:  
CRT611

# ADDITIONAL MATERIALS NEEDED FOR CONTROL PANEL ELECTRICAL INSTALLATION

<u>QUANTITY</u>	<u>ITEM</u>	<u>MANUFACTURER OR EQUAL</u>
As required	2#12UF with ground	
2	300 volt silicon filled underground service wire nuts	King-6T
As required	Conduit and fittings are as shown in the drawings contained in this manual.	
1	20 amp minimum A/C Type disconnect switch or equal. Required on CP20 series panels only	

**APPENDIX C**  
**AIR PUMP DRAWINGS AND PARTS LIST**

# DRAWING & PARTS LISTS

	MODEL 5030/5040	MODEL 5060	MODEL 5070		
Item No.	Part No.	Part No.	Part No.	Description	Qty.
1	C50145	C50156	C50165	Diaphragm	2
2	C50146	C50157	C50157	Diaphragm Base	2
3	C50147	C50191	C50148	Head & Valve Assembly	2
4	C50151	C50159	C50161	Shuttle Assembly (Includes Washer, U-Lock Nut, Magnet)	1
5	C50152	C50152	C50152	Air Cleaner	1
6	C50153	C50153	C50153	Lock Knob	1
7	C50154	C50154	C50154	Plastic Cover (Air Cleaner)	1
8	C50142	C50142	C50142	Vibration Mount	4
9	C50143	C50143	C50143	Rubber Bumper	4
10	C50155	C50155	C50155	L-Tube	2
11	—	—	C50164	Micro Switch	1

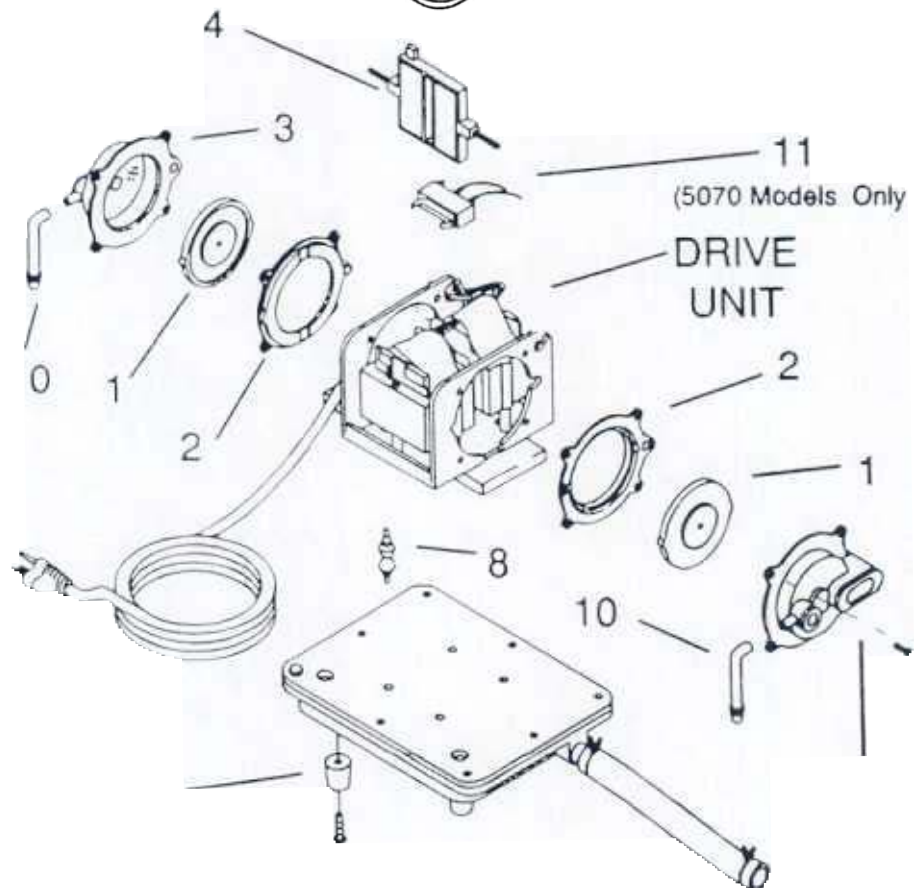
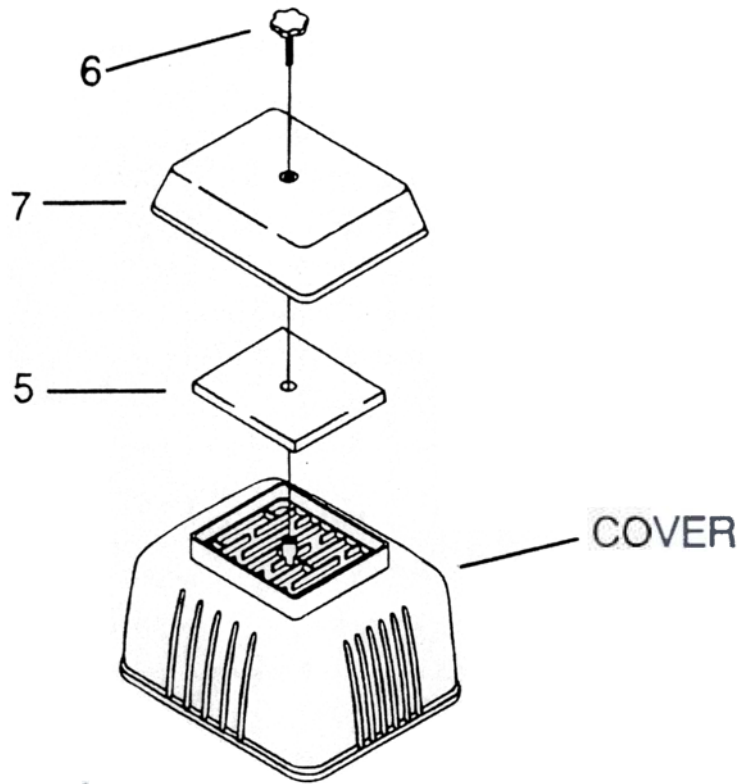

# Drawing & Parts List

	MODEL	MODEL	MODEL	MODEL	MODEL	MODEL		
	5030-A 5030V-A 5010-A 5040V-A	5060 5060V-A	5070-A 5070V-A	5030M0 5040M0	5060M0	5070M0		
Item No.	Part No.	Part No.	Part No.	Part No.	Part No.	Part No.	Description	Qty.
1	C50146	C50157	C50157	C50146	C50157	C50157	Diaphragm Assembly	2
	C50145	C50165	C50165	C50145	C50165	C50165	Diaphragm (Only)	2
2	C50190	C50191	C50189	C50190	C50191	C50189	Head & Valve Assembly	2
3	C50151	C50159	C50161	C50151	C50159	C50161	Shuttle Assembly (Includes Washer, U-Lock Nut Magnet)	1
4	C5630J	C56300	C56300	-	-	-	Air Cleaner	1
5	C50213	C50213	C50213	-	-	-	Lock Screw	1
6	C53006	C53006	C53006	-	-	-	Plastic Cover (Air Cleaner)	1
7	C50101	C50101	C50101	-	-	-	Rubber Bumper	4
8	C50214	C50214	C50214	-	-	-	L-Tube	2
9	-	-	C50164	-	-	C50164	Micro Switch	1
10	C56008	C56008	C56008	-	-	-	Tank Gasket	1
11	C55002	C55002	C55002	-	-	-	Hose Kit <i>(Includes 2 Clamps, 1 Hose, 1 Barb Fitting)</i>	1

Not used on Vacuum Models

Note: 'Motor Only' units do not include a power cord

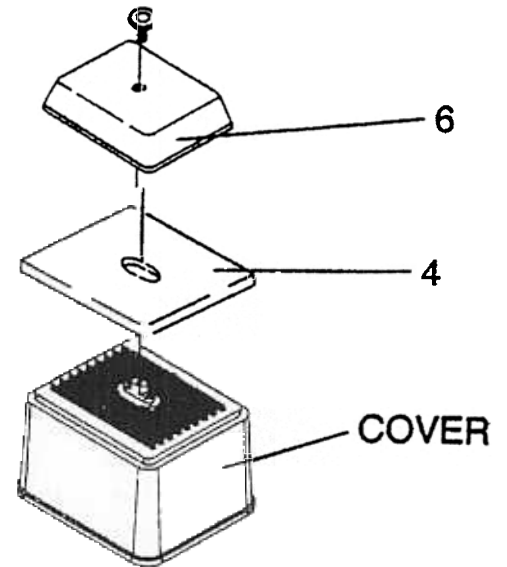

REBUILD KITS			
(KITS INCLUDE DIAPHRAGM ASSEMBLY AND HEAD & VALVE ASSEMBLY)			
(PART NOS. 1 & 2)			
Model	Part No.	Qty.	
5030 &	C50278	2	
5040	C50276	2	
5060	C50277	2	

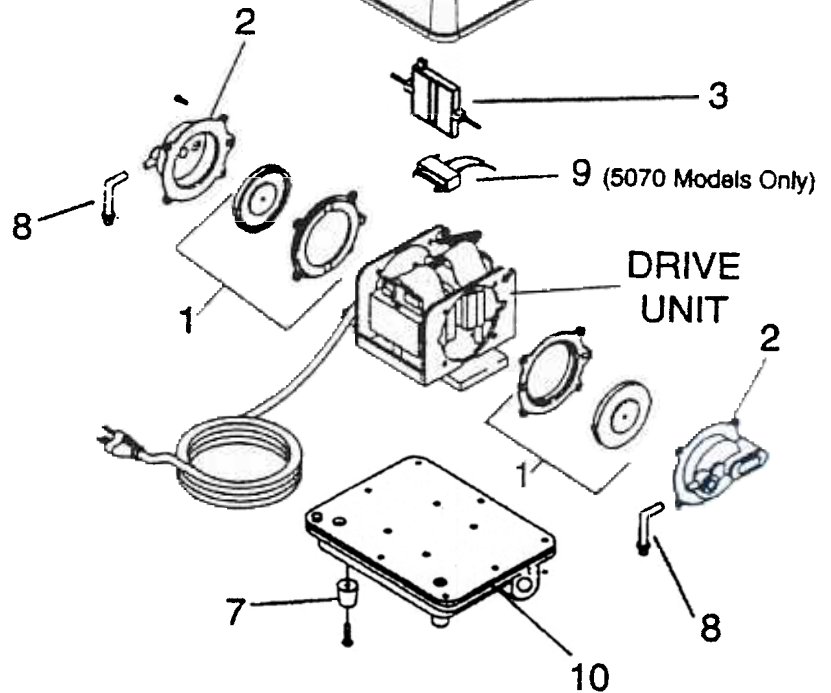

# DRAWING & PARTS LISTS

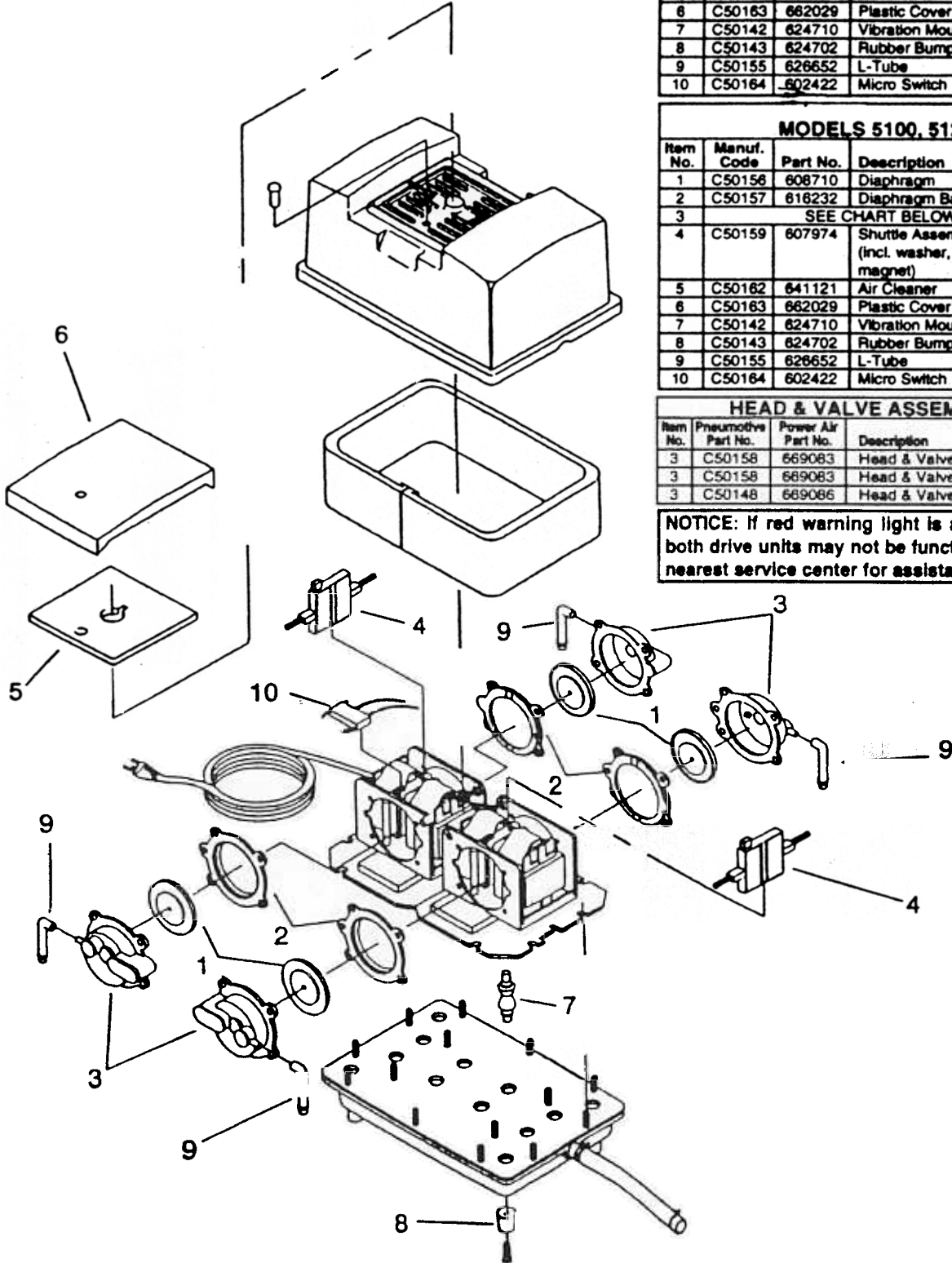

MODELS 5080				
Item No.	Manuf. Code	Part No.	Description	Qty.
1	C50145	608709	Diaphragm	4
2	C50157	616232	Diaphragm Base	4
SEE CHART BELOW				
4	C50151	607973	Shuttle Assembly (incl. washer, u-lock nut, magnet)	2
5	C50182	641121	Air Cleaner	1
6	C50163	662029	Plastic Cover (Air Cleaner)	1
7	C50142	624710	Vibration Mount	8
8	C50143	624702	Rubber Bumper	4
9	C50155	626652	L-Tube	4
10	C50164	602422	Micro Switch	2

MODELS 5100, 5120				
Item No.	Manuf. Code	Part No.	Description	Qty.
1	C50156	608710	Diaphragm	4
2	C50157	616232	Diaphragm Base	4
SEE CHART BELOW				
4	C50159	607974	Shuttle Assembly (incl. washer, u-lock nut, magnet)	2
5	C50182	641121	Air Cleaner	1
6	C50163	662029	Plastic Cover (Air Cleaner)	1
7	C50142	624710	Vibration Mount	8
8	C50143	624702	Rubber Bumper	4
9	C50155	626652	L-Tube	4
10	C50164	602422	Micro Switch	2

HEAD & VALVE ASSEMBLIES					
Item No.	Pneumoths Part No.	Power Air Part No.	Description	Model No.	Qty.
3	C50158	669083	Head & Valve Assy.	5080	4
3	C50158	669083	Head & Valve Assy.	5100	4
3	C50148	669086	Head & Valve Assy.	5120	4

**NOTICE:** If red warning light is activated, one or both drive units may not be functioning. Call your nearest service center for assistance.

# DRAWING & PARTS LIST

	MODEL 5078S 5080S 5100S 5120S	MODEL 5150S 5200S	MODEL 5078SE 5080SE 5100SE 5120SE	MODEL 5150SE 5200SE		
Item No.	Part No.	Part No.	Part No.	Part No.	Description	Qty.
1	C51800	C51802	C51800	C51802	Diaphragm Assembly	2
2	C52000	C52700	C52000	C52700	Head & Valve Assembly	2
3	C56301	C56302	-	-	Air Cleaner	1
4	C56002	C56005	-	-	Filter Cover Gasket	1
5	C53900	C53903	-	-	L-Tube	2
6	C50262	C50263	C50262	C50263	Protective Switch	1
7	C53008	C53009	-	-	Filter Cover	1
9	C50284	C50285	-	-	Tank Gasket	1

SHUTTLE ASSEMBLY (ITEM 8)			
Model	Part No.	Qty.	
5078S, 5078SE	C50272	1	
5080S, 5080SE	C51600	1	
5100S, 5100SE	C51601	1	
5120S, 5120SE	C51602	1	
5150S, 5150SE	C51400	1	
5200S, 5200SE	C50265	1	

REBUILD KITS (KITS INCLUDE DIAPHRAGM ASSEMBLY AND HEAD & VALVE ASSEMBLY) (PART NOS. 1 & 2)			
Model	Part No.	Qty.	
5078S, 5078SE 5080S, 5080SE 5100S, 5100SE 5120S, 5120SE	C50280	2	
5150S, 5150SE 5200S, 5200SE	C50281	2	

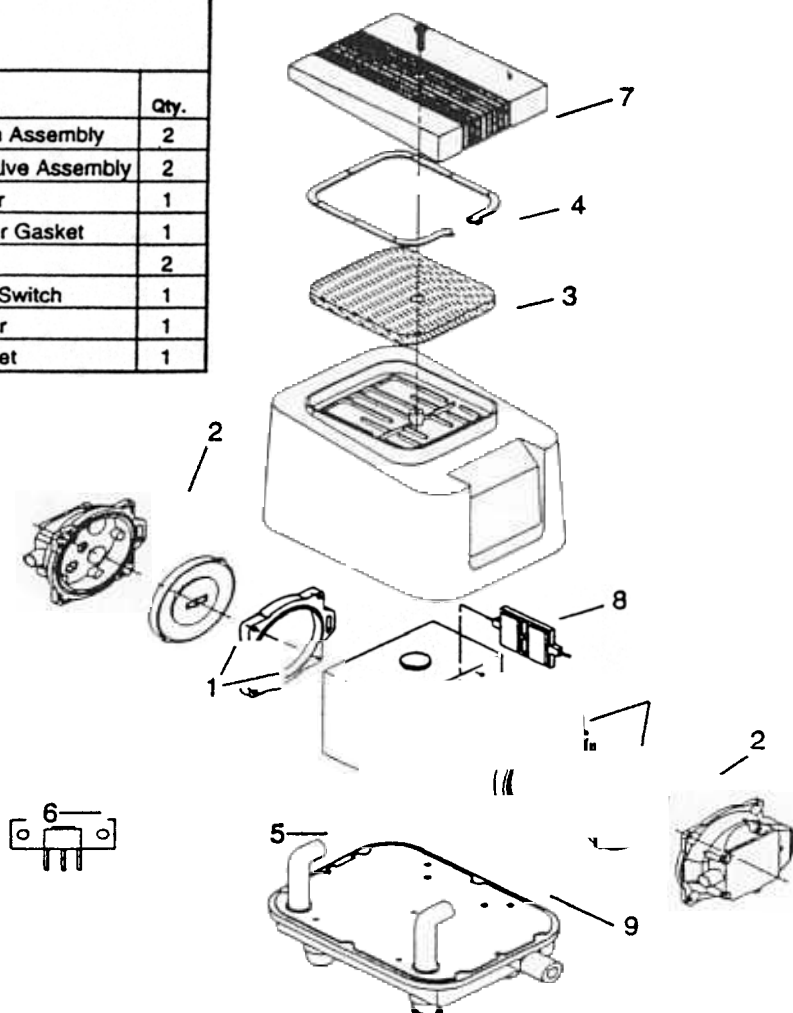

# SAR-0030, SAR-0040, SAR-0060 PARTS LIST

NOTE: Teflon tape is not recommended when installing intake filters and will void the factory warranty.

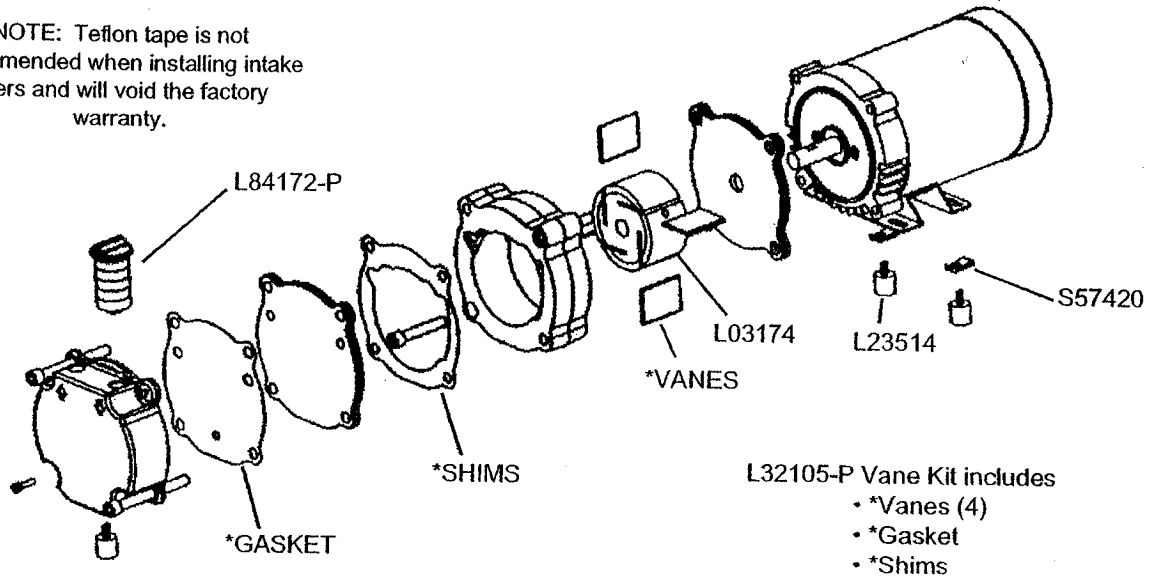

# PARTS LIST

QR-0030

QR-0050

QR-0080

QR-0100

REF. NO.	DESCRIPTION	PART QTY.	291305 QR-0030	291306 QR-0050	291303 QR-0080	291304 QR-0100
1	SILENCER	1	C60362			C60363-P
2	VANE KIT [(4) VANES, GASKET]	1	L32100-P			L32103-P
3	ENDPLATE	1	L07163			L07166
4	SOUND CHAMBER	1	L07164			L07165
5	GASKET	1	L31058			L31059
6	SHROUD	1	L38230			L38231
7	FILTER KIT [(8) FELTS, (2) O-RINGS]	1	L84194-P			L84195-P
8	MOTOR	1	L36236			L36235
-	SHIM .0010 THICK	A/R*	L10556			L10569 (0.001)
-	SHIM .0015 THICK	A/R*	L10557			L10570 (0.015)
-	SHIM .0020 THICK	A/R*	L10558			L10571 (0.002)

\*AS REQUIRED

# EXPLODED VIEW

QR-0030  
QR-0050  
QR-0080  
QR-0100

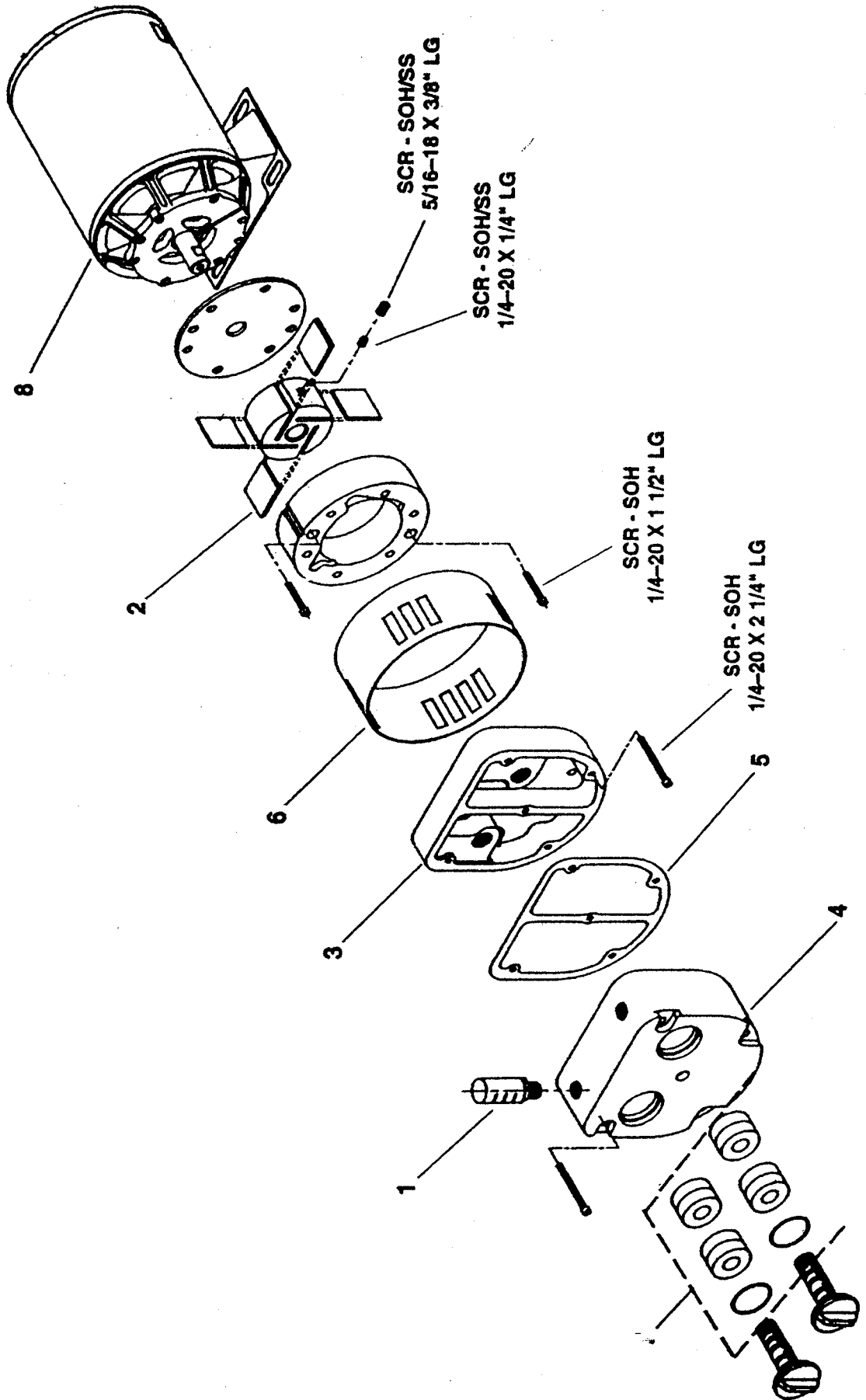

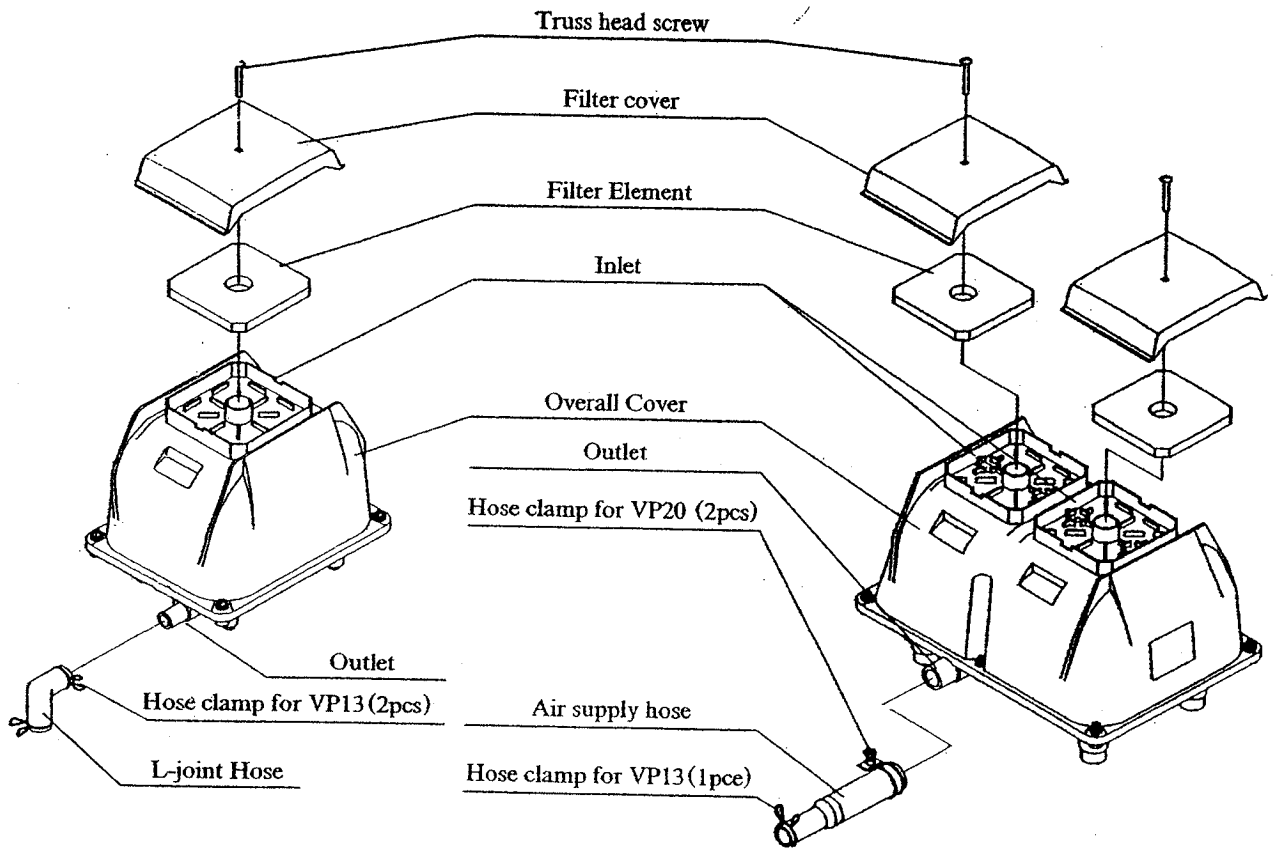

EL-60, 80-15, 80-17, 100

EL-120W, 150, 200

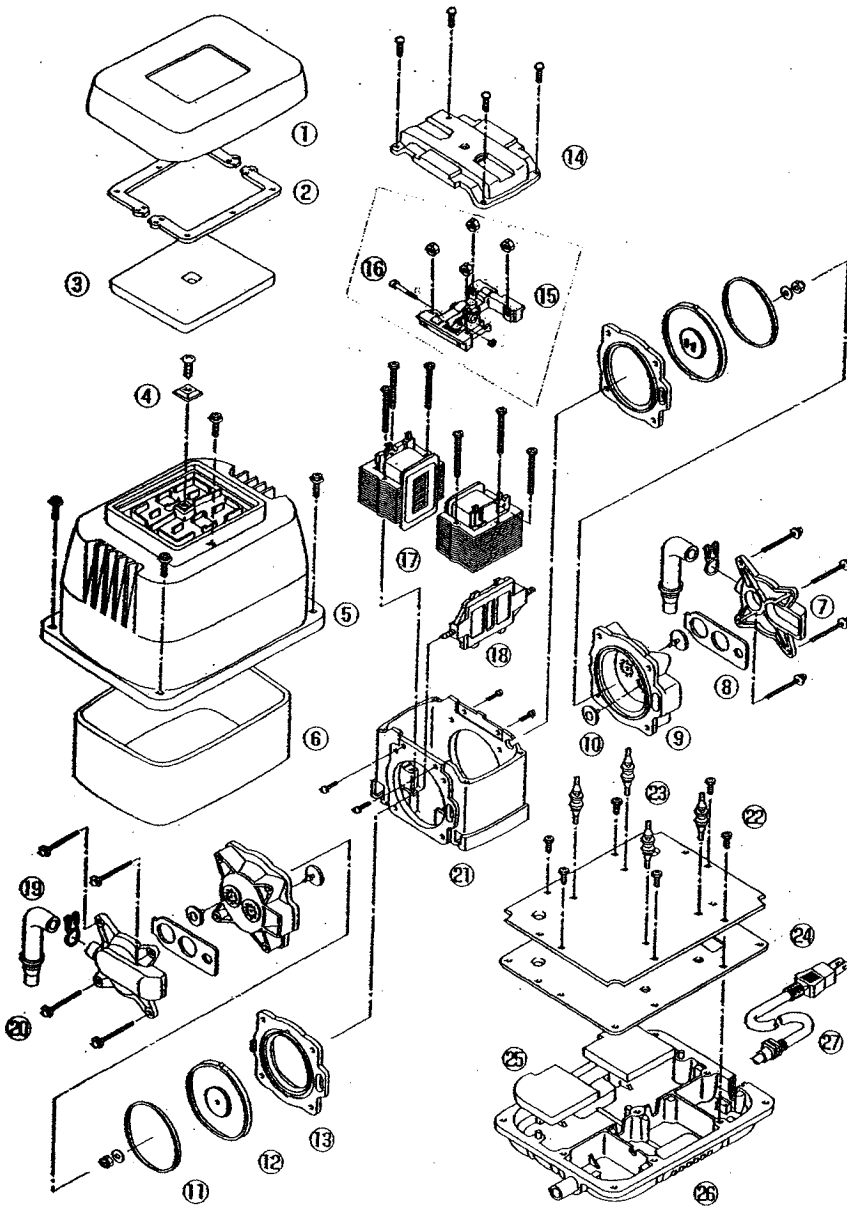

### HP-100/120

- ① Filter Cover
- ② Semi Cover Packing
- ③ Filter
- ④ Fitting Boss
- ⑤ Upper Housing
- ⑥ Sound Absorber (Lap)
- ⑦ Casing Block A
- ⑧ Valve Chamber Packing
- ⑨ Casing Block B
- ⑩ Valve
- ⑪ Diaphragm Ring
- ⑫ Diaphragm
- ⑬ Diaphragm Base
- ⑭ Frame Cover
- ⑮ SP Switch
- ⑯ Safety Screw
- ⑰ Electromagnet
- ⑱ Actuating Rod
- ⑲ L-Tube
- ⑳ Hose Band
- ㉑ Frame
- ㉒ Vibration Control Rubber
- ㉓ Center Plate
- ㉔ Gasket
- ㉕ Sound Absorber (Filter)
- ㉖ Lower Housing
- ㉗ Power Cord

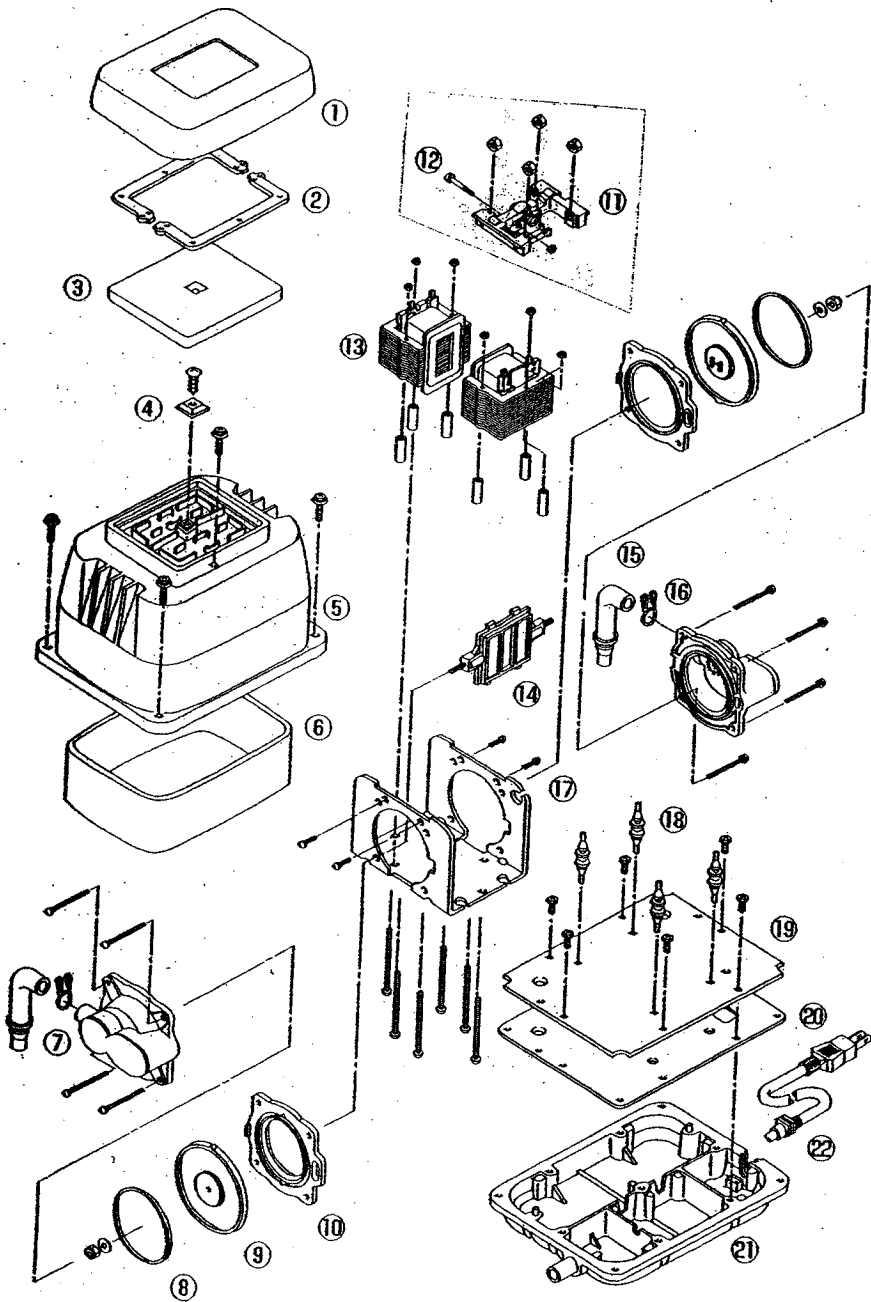

### HP-60/80

- ① Filter Cover
- ② Semi Cover Packing
- ③ Filter
- ④ Fitting Boss
- ⑤ Upper Housing
- ⑥ Sound Absorber
- ⑦ Casing Block
- ⑧ Diaphragm Ring
- ⑨ Diaphragm
- ⑩ Diaphragm Base
- ⑪ SP Switch
- ⑫ Safety Screw
- ⑬ Electromagnet
- ⑭ Actuating Rod
- ⑮ L-Tube
- ⑯ Hose Band
- ⑰ Frame
- ⑱ Vibration Control Rubber
- ⑲ Center Plate
- ⑳ Gasket
- ㉑ Lower Housing
- ㉒ Power Cord

**APPENDIX D  
NAMEPLATES**

# TREATMENT PLANT DATA PLATES

4"

**WHITEWATER**

Delta Environmental Products™

Pentair Water

8275 Florida Boulevard

Denham Springs, LA 70726

Phone: 1-800-219-9183

Model DF XXX-X

ANSI/NSF STD 40

XXX GPD Class I



Serial No.

2"

4"

**ALARM MALFUNCTION ELECTRICAL PANEL**

**WHITEWATER**

Delta Environmental Products™

Pentair Water

8275 Florida Boulevard

Denham Springs, LA 70726

Phone: 1-800-219-9183

Model DF XXX-X

ANSI/NSF STD 40

XXX GPD Class I



Serial No.

3"

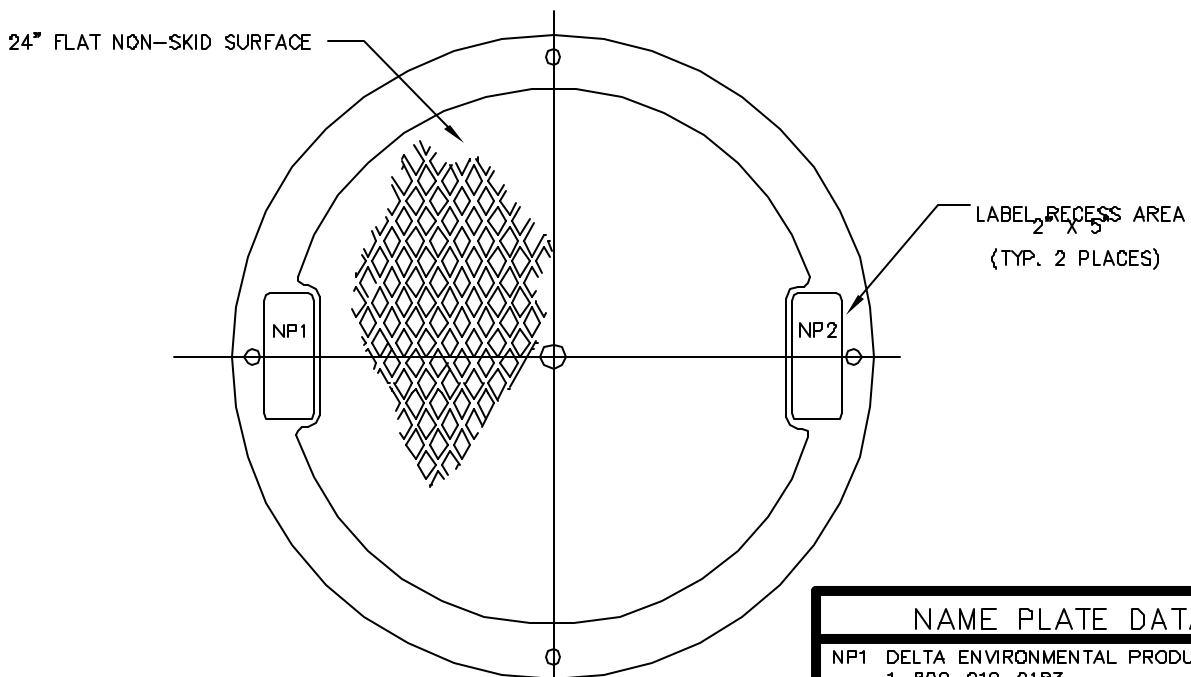
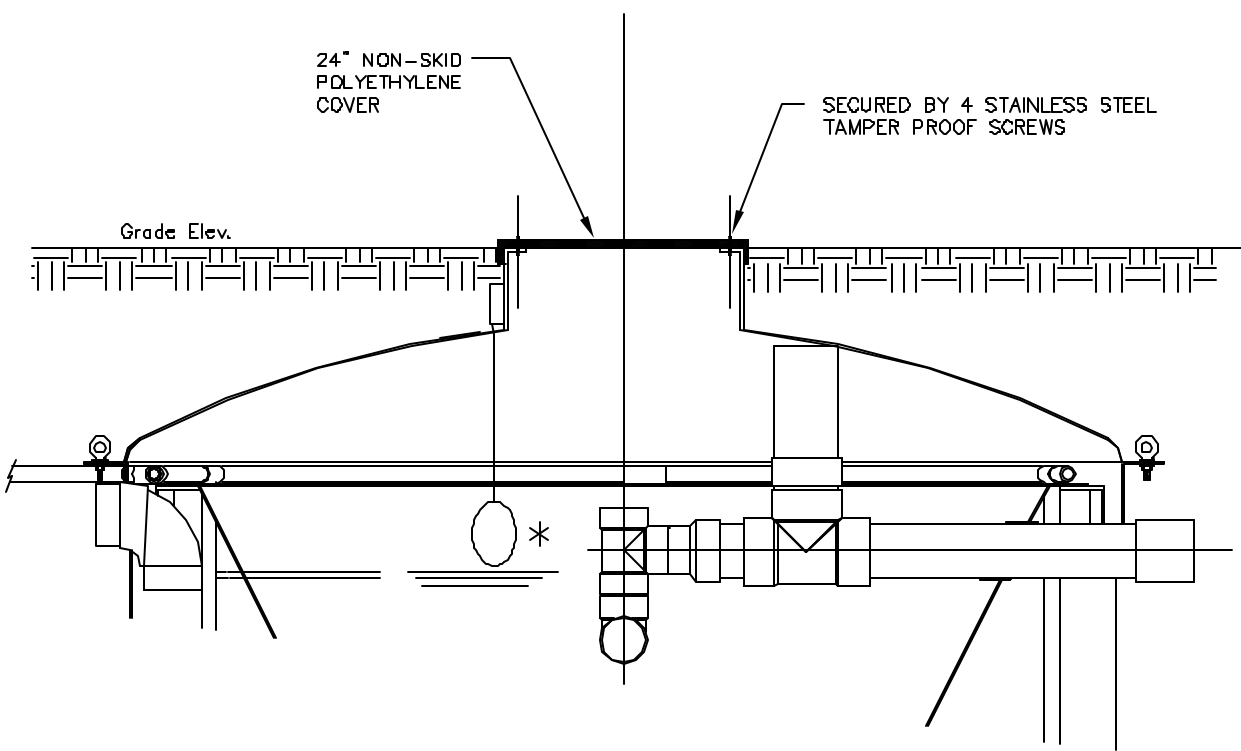

\* HIGH LEVEL FLOAT REQUIRED  
WHEN USING CP22 SERIES CONTROL PANELS

NAME PLATE DATA	
NP1	DELTA ENVIRONMENTAL PRODUCTS, INC. 1-800-219-9183
NP2	MODEL DFXX-X XXXX GPD ANSI/NSF STD 40 CLASS 1 SERIAL NO. XXXXX



DELTA ENVIRONMENTAL PRODUCTS, INC.  
P. O. BOX 969 DENHAM SPRINGS, LA 70727

### ALTERNATE ACCESS PORT MODEL DFXX-X

DWN BY:  
B.LANDRY

DATE:  
04/09/03

SCALE:  
N.T.S.

DWG. NO.:  
CRT613

**APPENDIX E**  
**SERVICE POLICY, WARRANTIES**  
**AND INSPECTION COUPONS**

# **DELTA ENVIRONMENTAL PRODUCTS INDIVIDUAL MECHANICAL WASTEWATER TREATMENT SYSTEM SERVICE POLICY**

## **INITIAL POLICY:**

A two year initial service policy shall be furnished to the user by the manufacturer or the distributor through the dealer. This policy is to be included in the purchase price from the seller of the system and shall provide the following:

1. **An inspection/service call every six months**, which includes inspection, adjustment, and servicing of the mechanical and electrical component parts as necessary to ensure proper function.
2. An effluent quality inspection every six months consisting of a visual check for color, turbidity, scum overflow, and an examination for odors.
3. If any improper operation is observed which cannot be corrected at that time, the user shall be notified immediately in writing of the conditions and the estimated date of correction. **THIS POLICY DOES NOT INCLUDE PUMPING SLUDGE FROM UNIT IF DEEMED NECESSARY.**

## **CONTINUING SERVICE POLICY:**

An annually renewable service policy affording the same coverage as the Initial Service Policy is available. Consult your dealer for pricing information.

## **PARTS:**

Replacement parts or components may be obtained from your local distributor or contact Delta Environmental Products™. for information.

## **COMPLAINTS:**

In order for Delta Environmental Products.™ to properly address complaints, we require that you put in writing the date and nature of the complaint as detailed as possible. This must include the Serial Number of your system.

Send to: Delta Environmental Products™  
P.O. Box 969  
Denham Springs, LA 70727-0969

# LIMITED WARRANTY

Delta Environmental Products™ warrants the parts in each treatment system as follows: air pump: limited pro-rated five (5) years - first two (2) years 100 %, third (3) year 75 %, fourth (4) year 50 %, fifth (5) year, 25 %), **The 3, 4, and 5 year pro-rated portion of this warranty is only valid with a continuing Service Policy in effect. Proof of this continuing Service Policy must be provided.** QR-Rotary compressor – limited 2 years, SAR – Rotary compressor – limited 3 years, fiberglass tanks: limited 10 years, metal tanks: limited 2 years, and concrete tanks: limited 2 years. All warranty questions shall be resolved through Delta Environmental Products™. The warranty on the treatment device is that the device is free from defects in material and workmanship from the date of installation treating household wastewater. Some states do not allow limitations on how long an implied warranty lasts, so the above limitation may not apply. Sole obligation under this warranty is as follows: Delta Environmental Products™ shall fulfill this warranty by repairing or exchanging any component part, F.O.B. factory that in Delta Environmental Products™ judgment shows evidence of defects, provided said component part has been paid for and is returned through an authorized dealer, transportation prepaid. The warrantee must also specify the nature of the defect to the manufacturer.

The warranty does not cover treatment processes/devices that have been flooded, by external means, or that have been disassembled by unauthorized persons, improperly installed, subjected to external damage or damaged due to altered or improper wiring or overload protection.

This warranty applies only to the treatment process/device and does not include any of the house wiring, plumbing, drainage, or disposal system. Delta Environmental Products™ is not responsible for any delay or damages caused by defective components or material, or for loss incurred because of interruption of service, or for any other special or consequential damages or incidental expenses arising from the manufacture, sale or use of this process/device.

Delta Environmental Products™ reserves the right to revise, change or modify the construction and design of the treatment process/device for household wastewater or any component part or parts thereof without incurring any obligation to make such changes or modifications in previously sold equipment. Delta Environmental Products™ also reserves the right, in making replacements of component parts under this warranty, to furnish a component part which, in its judgment is equivalent to the part replaced.

Under no circumstances will Delta Environmental Products™ be responsible to the warrantee for any other direct or consequential damages, including but not limited to lost profits, lost income, labor charges, delays in production, and/or idle production, which damages are caused by a defect in material and/or workmanship in its parts. Some states do not allow the exclusion of limitation of incidental or consequential damages, so the above limitation or exclusion may not apply to you.

This warranty is expressly in lieu of any other express or implied warranty, excluding any warranty of merchantability or fitness and of any other obligation on the part of Delta Environmental Products™.

This warranty gives you specific legal rights, and you may also have other rights which vary from state to state.